

# Refra VRF Troubleshooting

# Content

---

**01 Outdoor unit error code**

**02 Troubleshooting**

**03 Indoor unit error code**

**04 Troubleshooting**

# 01 Outdoor error code

## Outdoor unit error code

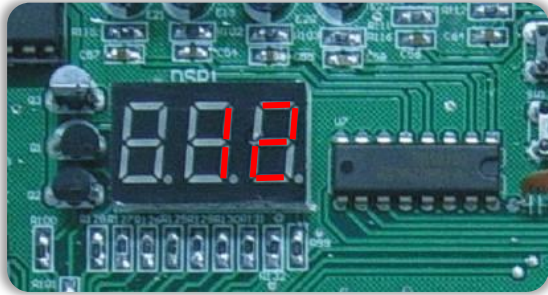

**12:** when in standby mode, it display the quantity of indoor units that can communication with outdoor unit in the system. In this example, **12** indoor units that can communication with outdoor unit in the system.

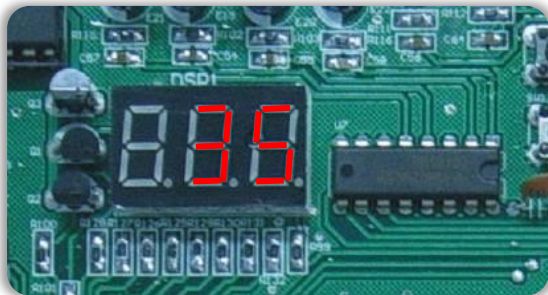

**35:** when outdoor unit is running, It display the frequency of inverter compressor. In this example, frequency of inverter compressor is **35Hz**.

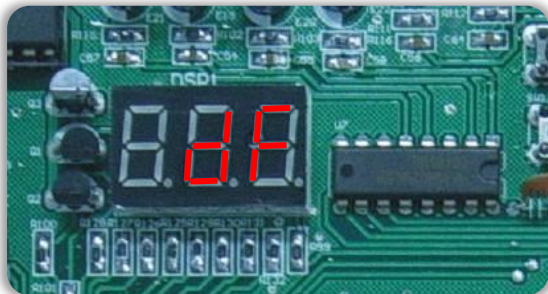

**dF:** when system is in defrost mode, it display “dF”

## *Outdoor unit error code*

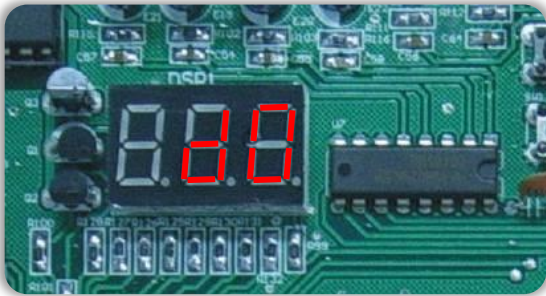

**d0:** when in oil return program, it display “d0”

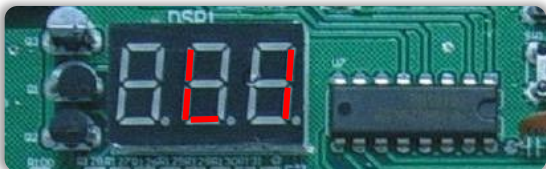
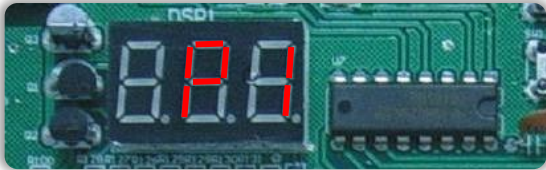
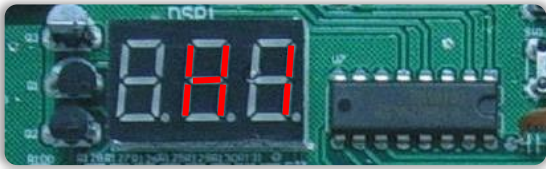
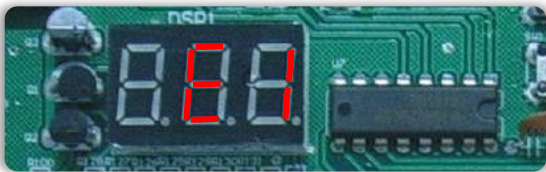

**When system is in error or protection mode, it display Error code or protection code.**

**Error code: E0, E2.....E9**

**Error code: H0,H2.....H9**

**Protection code: P1,P2.....P9**

**Error code after P6: L1,L2.....L9**

## ***Outdoor unit error code***

<b>Code</b>	<b>Malfunction or protection</b>	<b>remark</b>
<b>E0</b>	<b>Outdoor unit communication malfunction</b>	<b>Only slave unit displays</b>
<b>E1</b>	<b>Phase sequence malfunction</b>	
<b>E2</b>	<b>Communication between master outdoor unit and indoor units</b>	
<b>E3</b>	<b>reserved</b>	
<b>E4</b>	<b>Ambient temperature sensor malfunction</b>	
<b>E5</b>	<b>reserved</b>	
<b>E6</b>	<b>Outdoor heat exchanger temperature sensor malfunction</b>	
<b>E7</b>	<b>reserved</b>	
<b>E8</b>	<b>Outdoor unit address incorrect</b>	
<b>E9</b>	<b>reserved</b>	

## *Outdoor unit error code*

<b>Code</b>	<b>Malfunction or protection</b>	<b>remark</b>
<b>P0</b>	<b>Inverter temperature protection</b>	
<b>P1</b>	<b>High pressure protection</b>	
<b>P2</b>	<b>Low pressure protection</b>	
<b>P3</b>	<b>Inverter compressor over current protection</b>	
<b>P4</b>	<b>Discharge temperature sensor protection</b>	
<b>P5</b>	<b>Heat exchanger high temperature protection</b>	
<b>P6</b>	<b>Inverter module protection</b>	
<b>P7</b>	<b>Fix compressor 1 current protection</b>	
<b>P8</b>	<b>Fix compressor 2 current protection</b>	
<b>P9</b>	<b>Fan module protection</b>	

## **Outdoor unit error code**

<b>Code</b>	<b>Malfunction or protection</b>	<b>remark</b>
<b>H0</b>	<b>Communication malfunction between DSP and 0547</b>	
<b>H1</b>	<b>Communication malfunction between 0537 and 0547</b>	
<b>H2</b>	<b>Outdoor unit quantities decreasing malfunction</b>	<b>Only master unit displays</b>
<b>H3</b>	<b>Outdoor unit quantities increasing malfunction</b>	<b>Only master unit displays</b>
<b>H4</b>	<b>There are 3 times P6 protection in 30 minutes.</b>	<b>Repower on to clear the error code.</b>
<b>H5</b>	<b>There are 3 times P2 protection in 30 minutes.</b>	<b>Repower on to clear the error code.</b>
<b>H6</b>	<b>There are 3 times P4 protection in 100 minutes.</b>	<b>Repower on to clear the error code.</b>
<b>H7</b>	<b>Indoor unit quantities decreasing malfunction over 3 minutes</b>	<b>Recover when indoor unit quantity is correct</b>
<b>H8</b>	<b>Discharge pressure sensor error</b>	<b>When discharge pressure is lower than 0.3MPa</b>
<b>H9</b>	<b>There are 3 times P9 protection in 30 minutes.</b>	<b>Repower on to clear the error code.</b>

## Outdoor unit error code

Code	Malfunction or protection	remark
L0	Inverter compressor malfunction	After P6 displaying for 60s, they will display
L1	DC generatrix low voltage protection	
L2	DC generatrix high voltage protection	
L3	reserved	
L4	MCE malfunction/simultaneously/cycle loop	
L5	Zero speed protection	
L6	reserved	
L7	Wrong phase protection	
L8	Speed difference >15Hz protection between the front and the back clock	
L9	Speed difference >15Hz protection between the real and the setting speed	

## 02 Outdoor Troubleshooting

## E0: Communication error between outdoor units

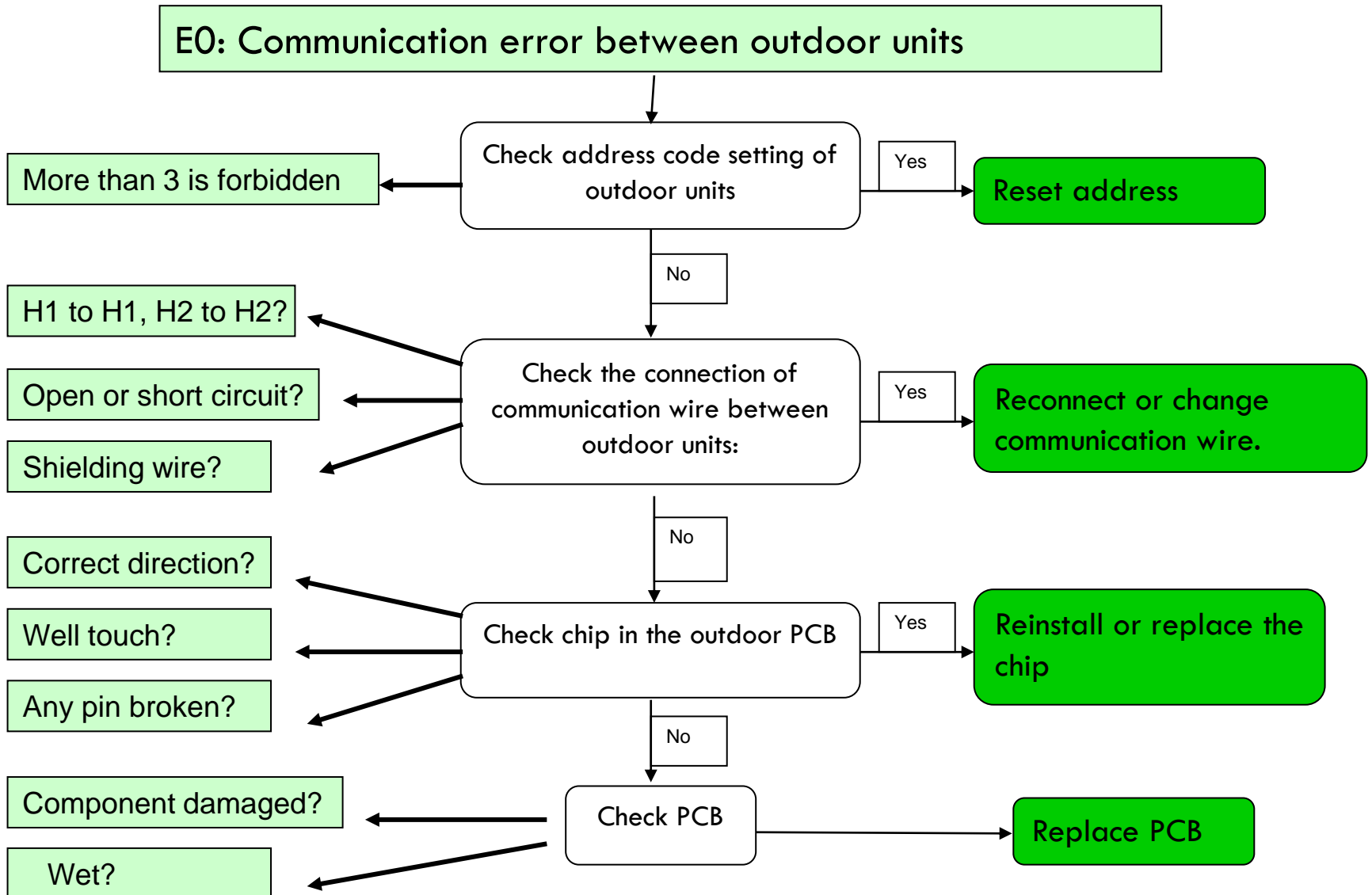

## ***E0: Communication error between outdoor units***

**1. Check the module address settings are correct or not.**

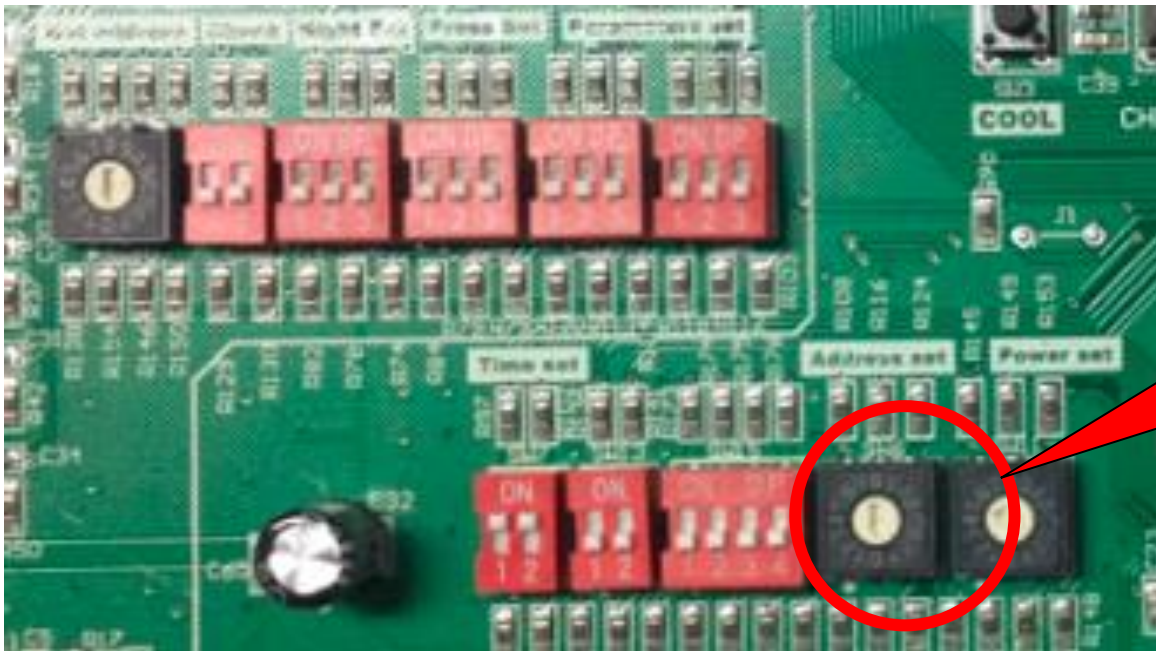

**Master unit dial to 0, slave units dial to other numbers (1,2 or 3), make sure no unit's address is repeat.**

**Solutions: If the address is not set correctly, reset address.**

## ***E0: Communication error between outdoor units***

**2. Check the communication wire between outdoor modules and make sure it is not loose, or in the wrong or short circuit condition.**

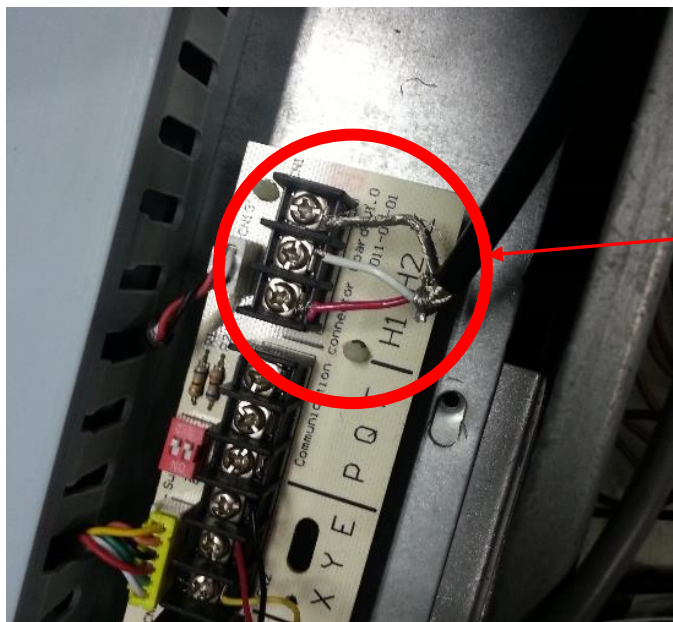

Pull the 3 wires and see whether it is loose

**Solutions: If there is loose wiring, wrong wiring or short circuit, then correct it, otherwise go to next step.**

## ***E0: Communication error between outdoor units***

**3. Check the outdoor module communication wire and electric control board terminals contact is loose; check the outdoor module communication wire and outdoor module communication terminal blocks contact is loose.**

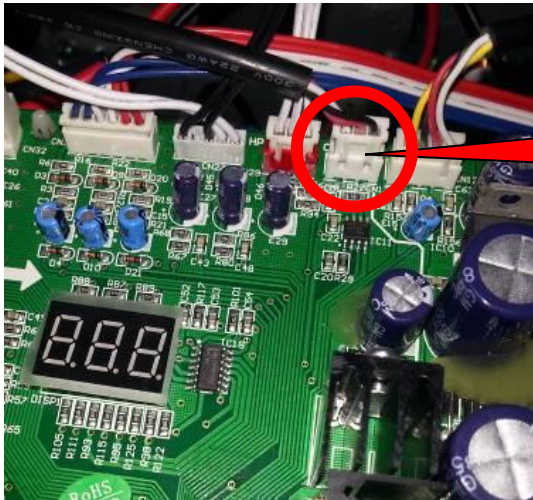

**Check the Plug  
for loose.**

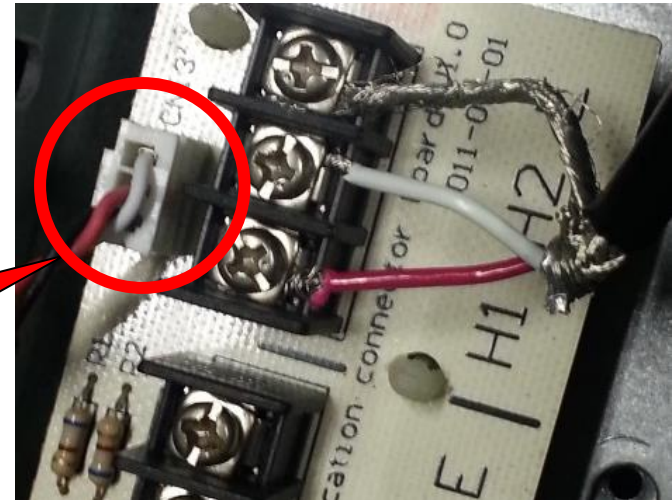

**Check the Plug  
for loose**

**Solutions: If the plug is loose, re-inserted, otherwise go to next step.**

## *E0: Communication error between outdoor units*

**4. Measure outdoor module communications cable resistance of H1, H2, E, and judge whether there is open circuit.**



**Solutions: If there is open circuit in the wire group (Resistance value is infinite), replace the wire group; if there is a open circuit between terminal blocks and the wire group, replace the terminal blocks.**

***E0: Communication error between outdoor units***

**5. Use 2-core shielded wire.**



**With shield layer**

## E1: Phase sequence reverse or lose

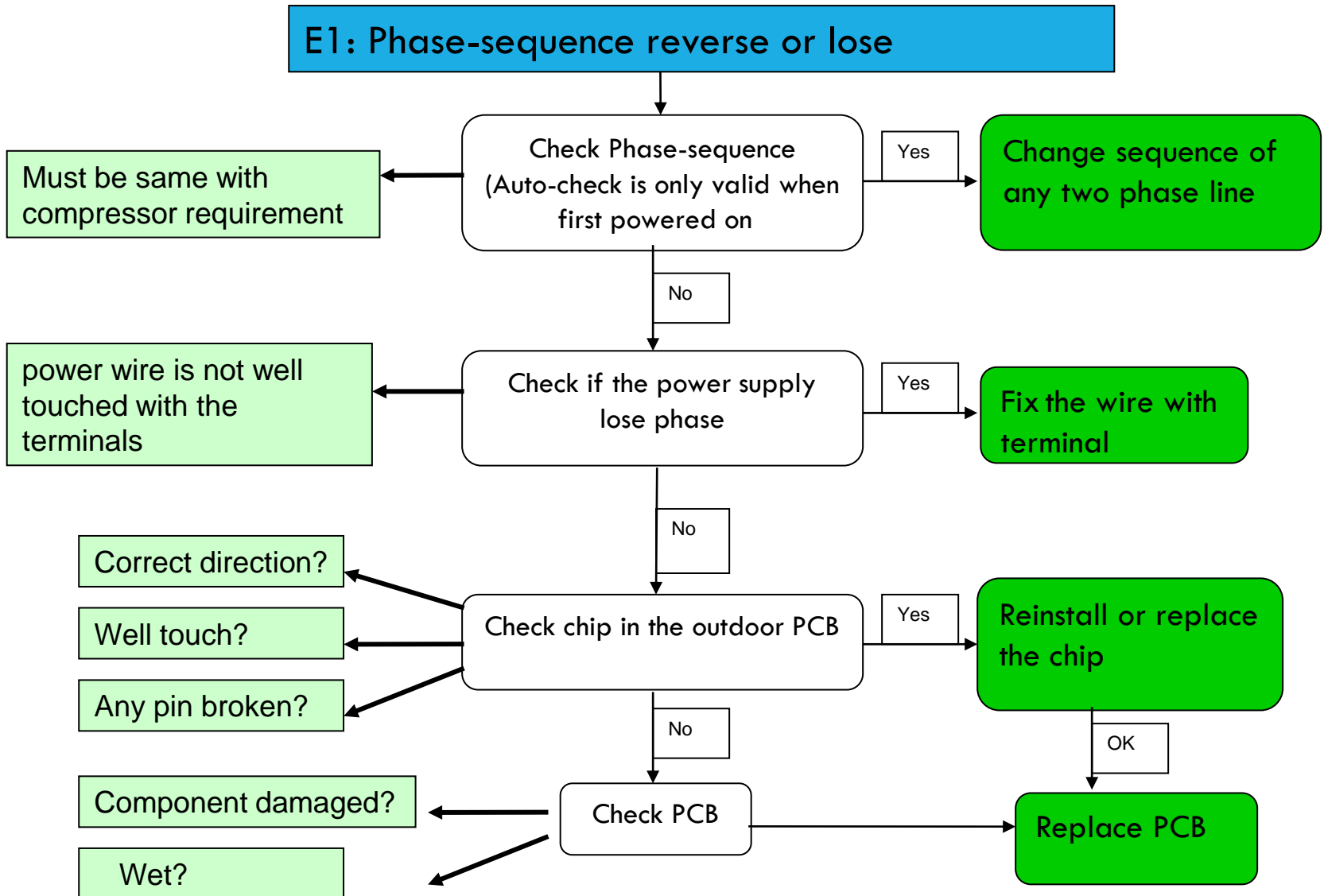

## ***E1: Phase sequence reverse or lose***

**1. Check the outdoor unit phase sequence and the power supply phase sequence are the same.**

**A,B,C terminal of three phase power supply should meet compressor phase sequence requirement. If not, error will display.**

**Solutions: If the phase sequence is incorrect, change the wiring, otherwise go to the next step.**

## ***E1: Phase sequence reverse or lose***

**2. Measure every phase voltage of terminal block, and determine whether there is a lack of phase.**



**Every phase voltage  
should be between  
220V-240V**

**Solutions: If the phase sequence is incorrect, change the wiring, otherwise go to the next step.**

**If there is a lack of phase, check the wiring and correct; if there is no lacking of phase, replace the main board of outdoor unit.**

## E2: Communication error between outdoor unit and indoor units

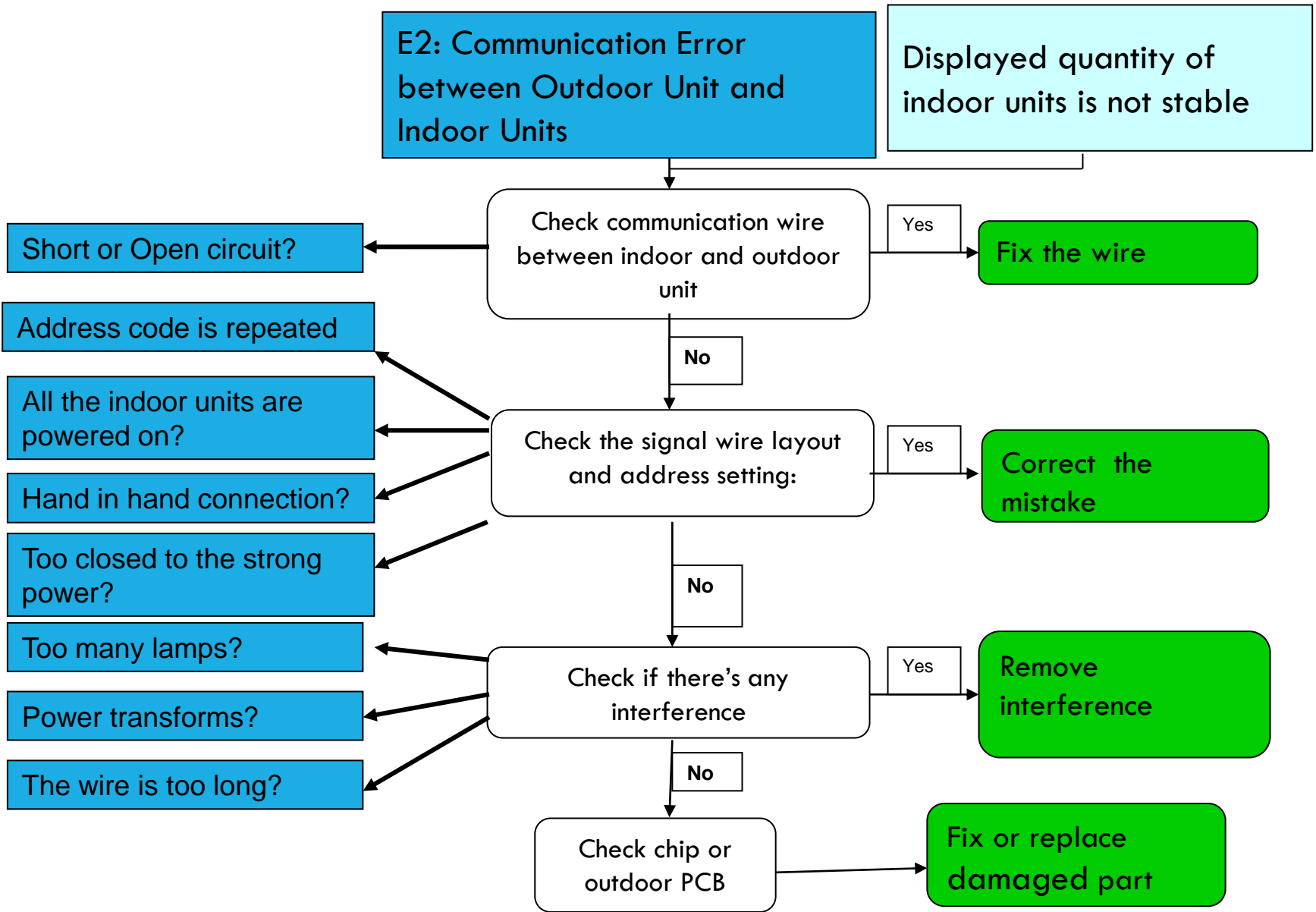

## ***E2: Communication error between outdoor unit and indoor units***

### **E2: Communication Error between Outdoor Unit and Indoor Units**

(20 minutes after powered on for the first time or the communication between indoor units and outdoor unit fail for 2 minutes)

**1. Check the communication line on the terminal blocks are not loose, or in the wrong or short-circuit condition.**

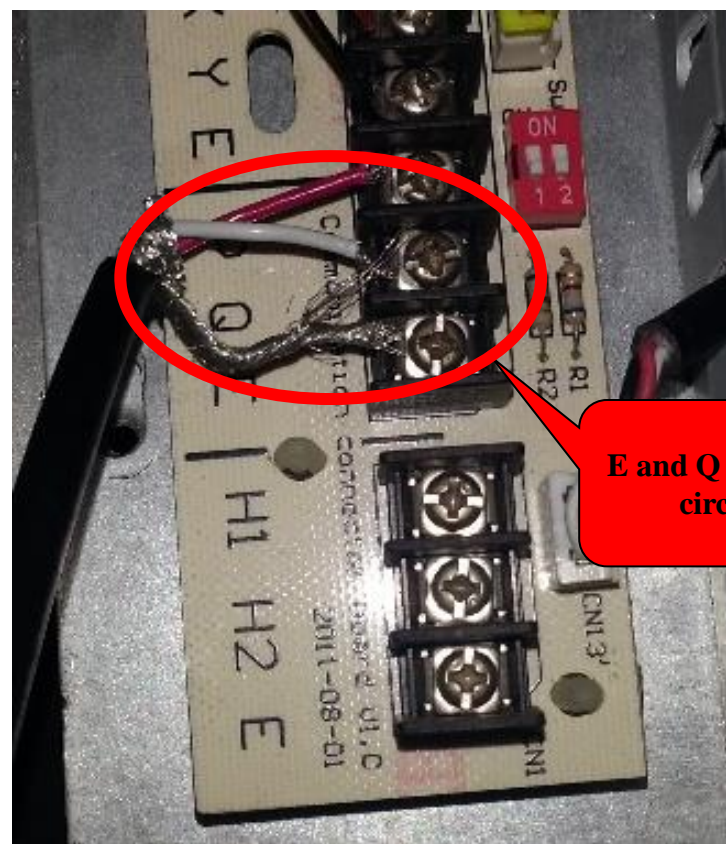
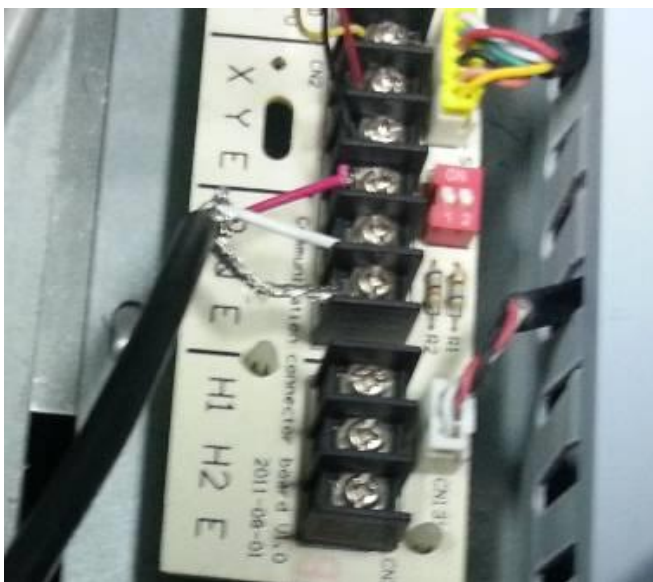

**Solutions: If the wiring is incorrect, change the wiring, otherwise go to the next step.**

## ***E2: Communication error between outdoor unit and indoor units***

**2. Check the indoor & outdoor communication wire and indoor & outdoor communication terminal blocks contact is loose.**

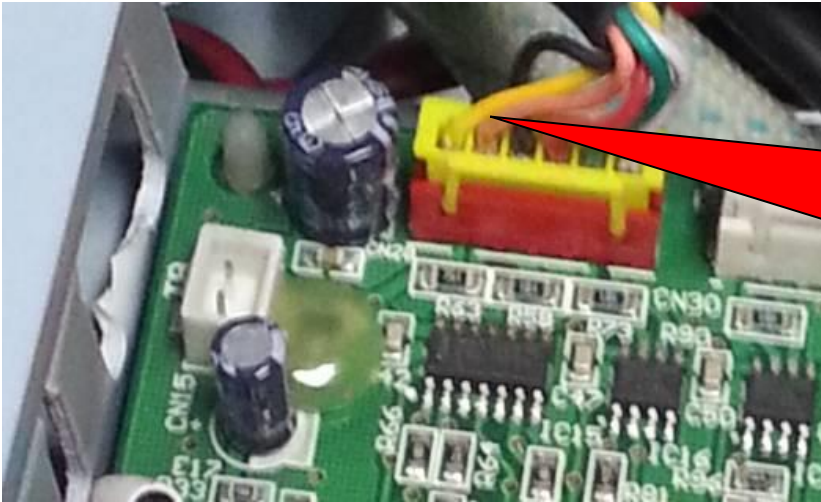

**Yellow, orange and black wires are indoor and outdoor communication wire**

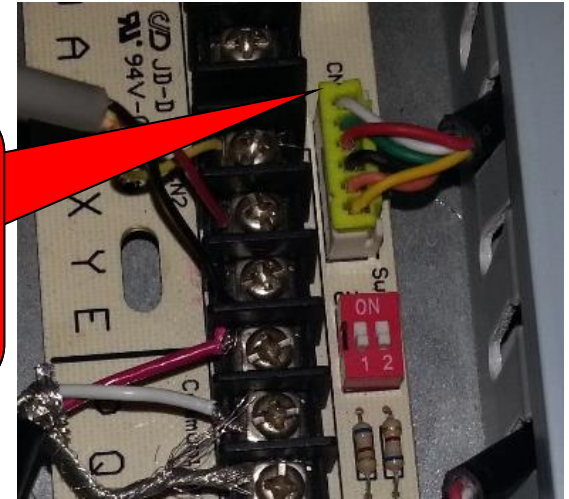

**Solutions: If the plug is loose, re-inserted, otherwise go to next step.**

## ***E2: Communication error between outdoor unit and indoor units***

**3. Measure indoor & outdoor communications cable resistance of P, Q, E, and judge whether there is open circuit.**

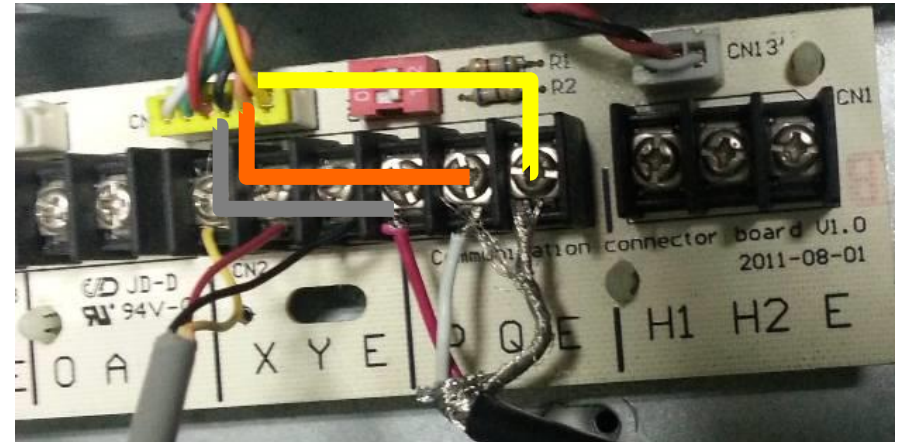
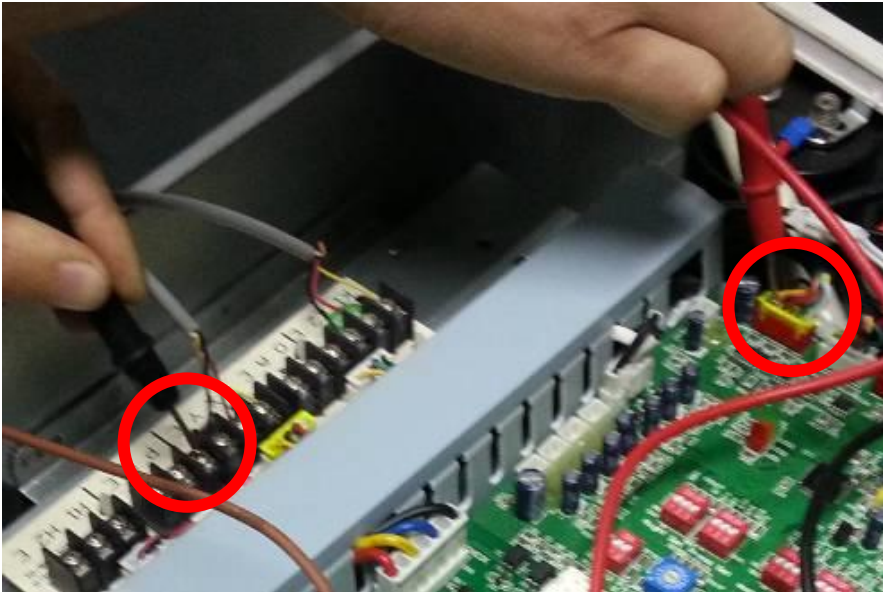

**Solutions:** If there is open circuit in the wire group, replace the wire group; if there is open circuit in the terminal block, then replace the terminal block; otherwise go to next step.

## ***E2: Communication error between outdoor unit and indoor units***

**4. Measure indoor & outdoor communications cable resistance of P, Q, E, and judge whether there is short circuit.**



**In the case of the system is power down, measure the resistance. If the resistance is 0.1 Ω indicates a short circuit; If MΩ or OL is normal.**

**Solutions: If there is short circuit in the indoor units communications cables, correct it; if there is no short circuit, then replace the main control board.**

## *E2: Communication error between outdoor unit and indoor units*

### **5. Communication wires must be hand in hand connection.**

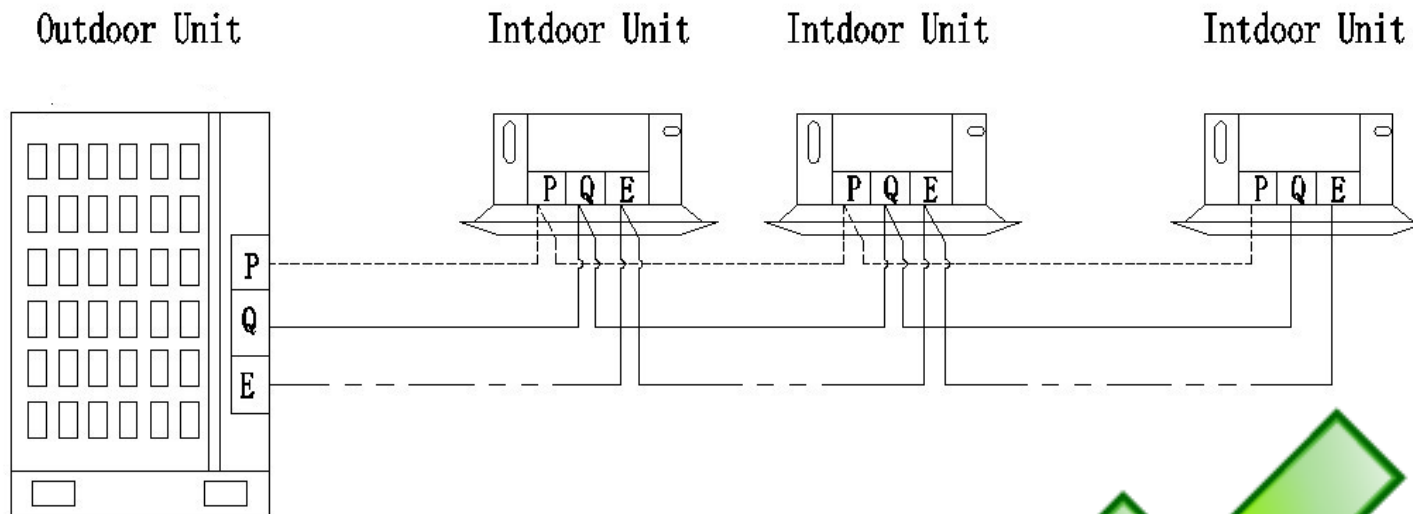

**Solutions: Hand in hand connection.**

**E2: Communication error between outdoor unit and indoor units**

**5. Communication wires must be hand in hand connection.**

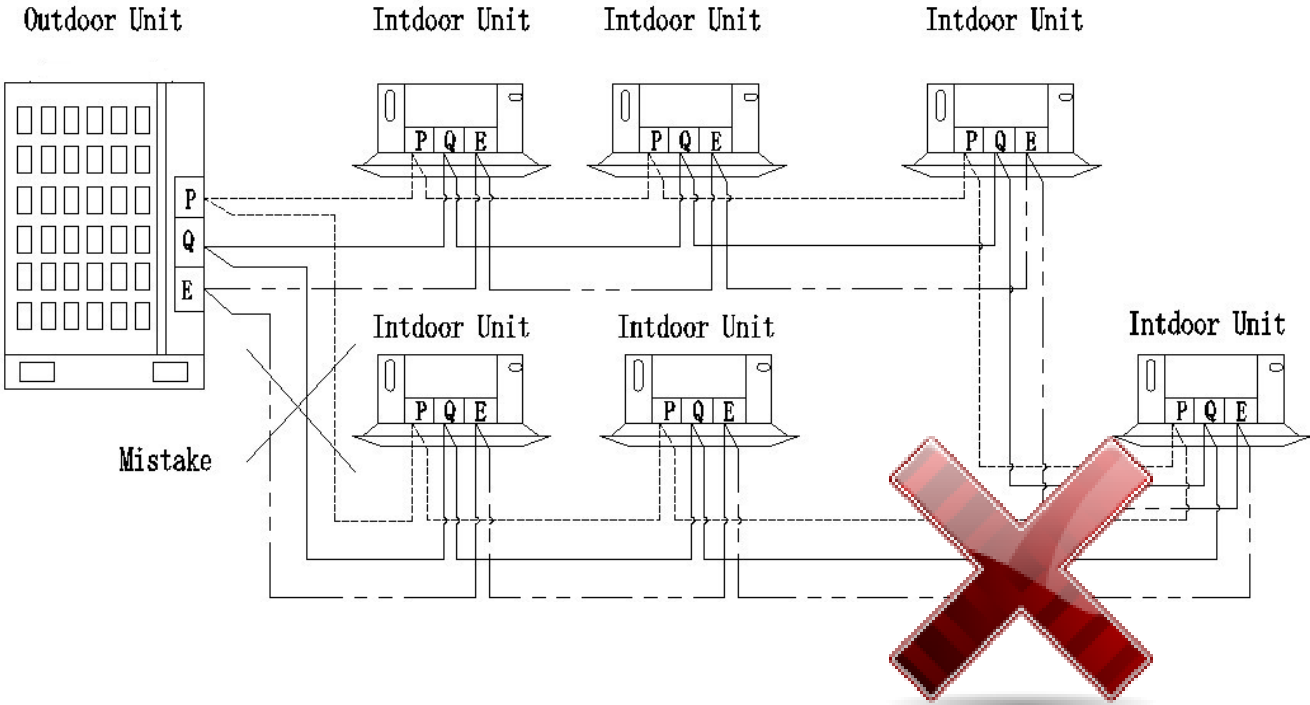

***E2: Communication error between outdoor unit and indoor units***

**5. Communication wires must be hand in hand connection.**

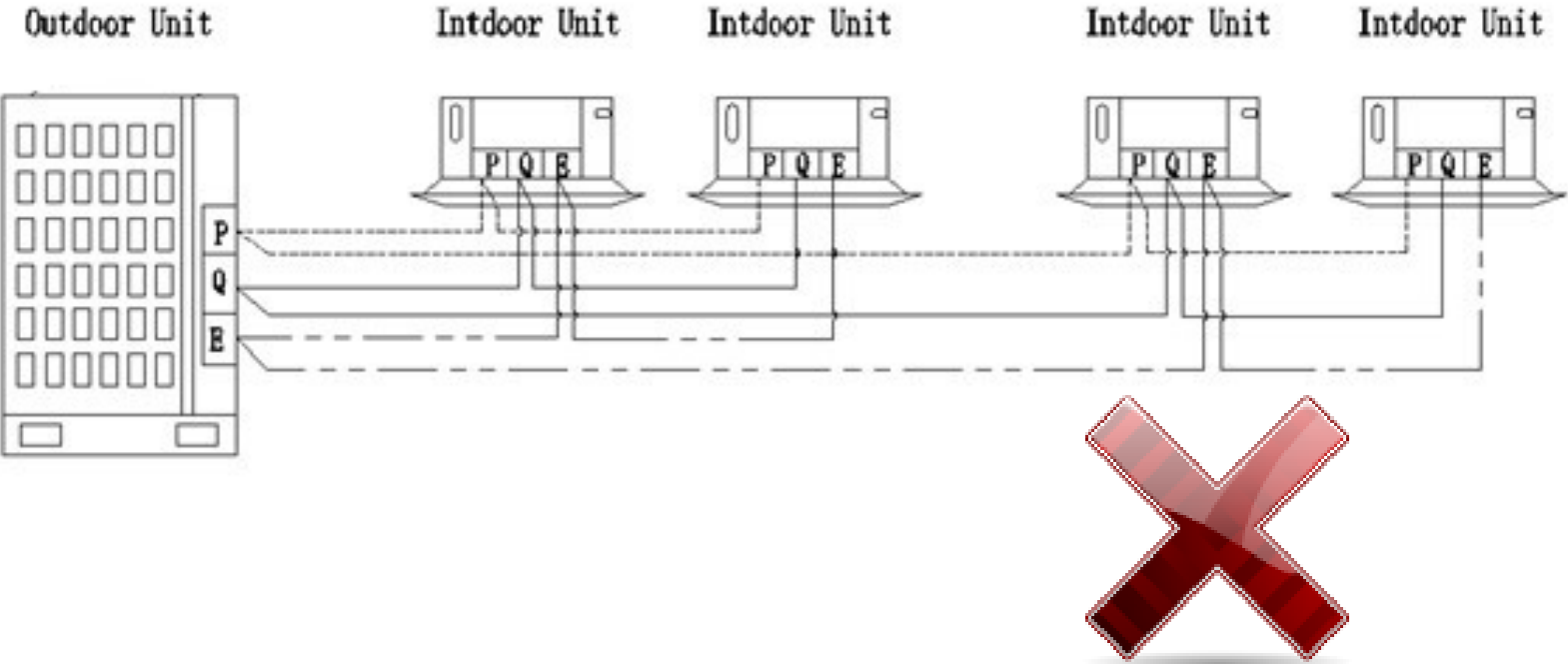

**E2: Communication error between outdoor unit and indoor units**

**5. Communication wires must be hand in hand connection.**

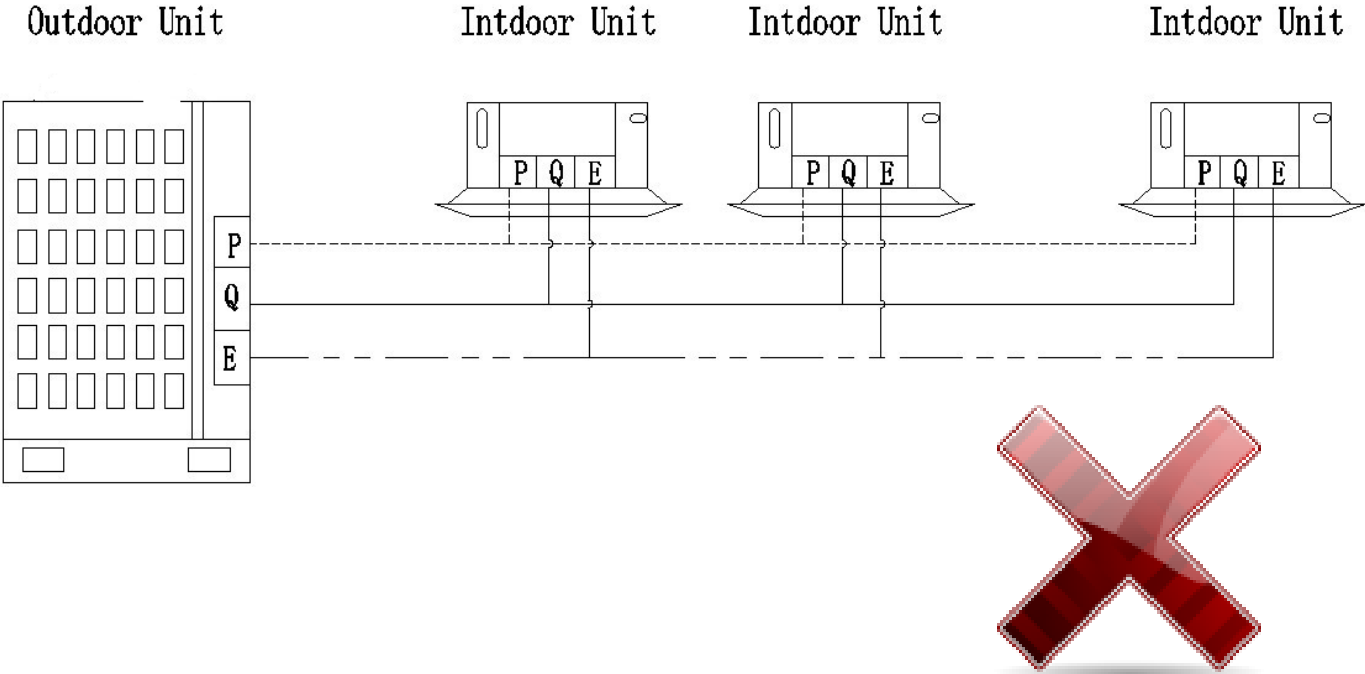

**E2: Communication error between outdoor unit and indoor units**

**5. Communication wires must be hand in hand connection.**

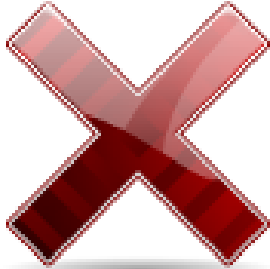
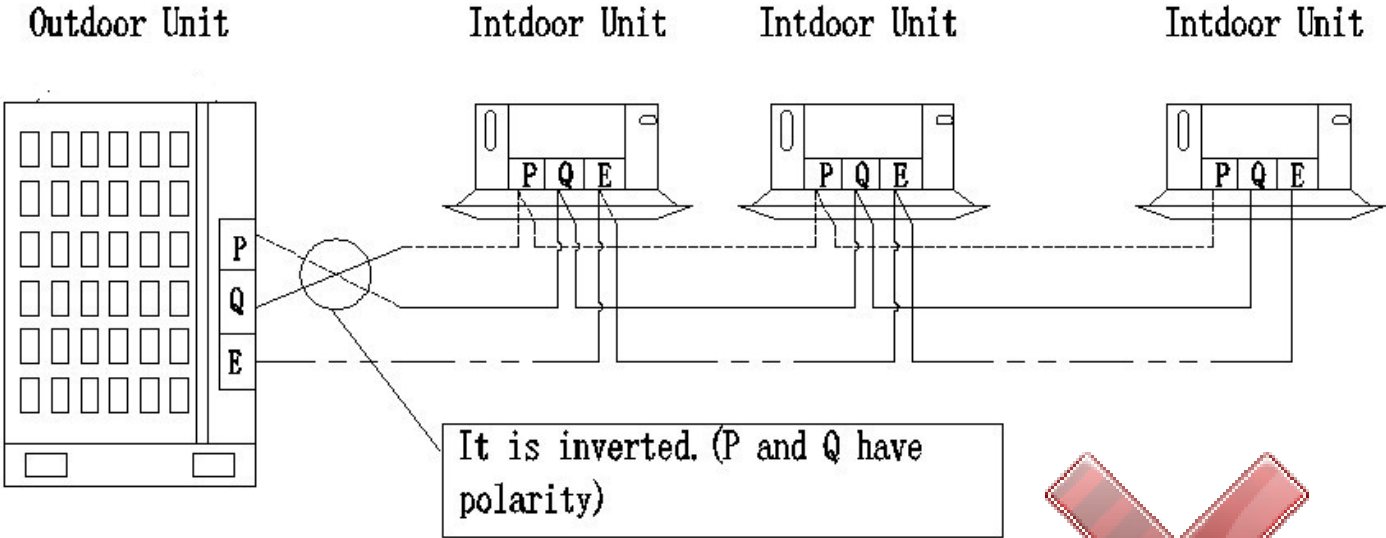

## E4: Outdoor ambient temperature sensor(T4) error

### E4: Outdoor ambient temperature sensor(T4) error

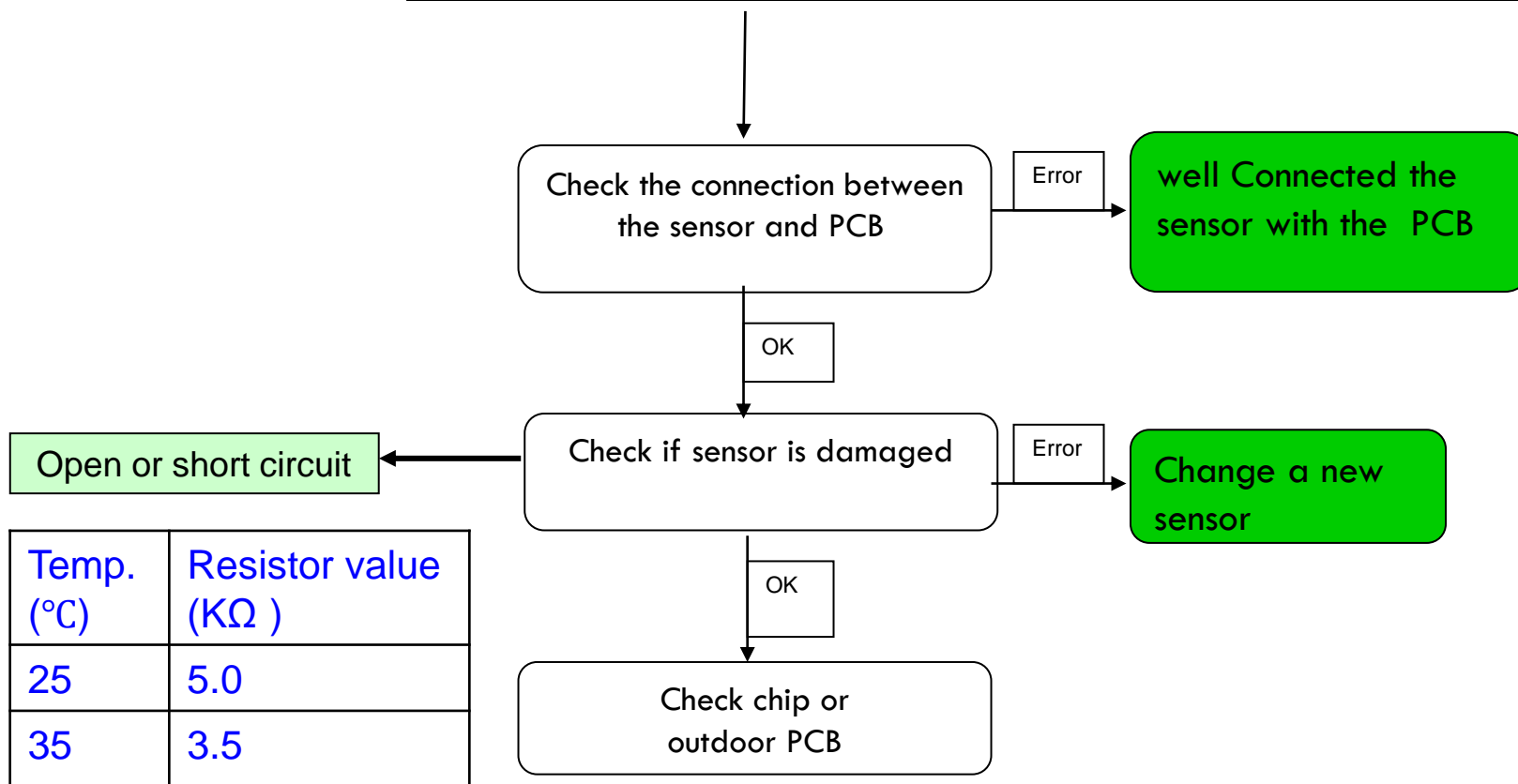

## ***E4: Outdoor ambient temperature sensor(T4) error***

### **1. Check the ambient temperature sensor connector for loose**

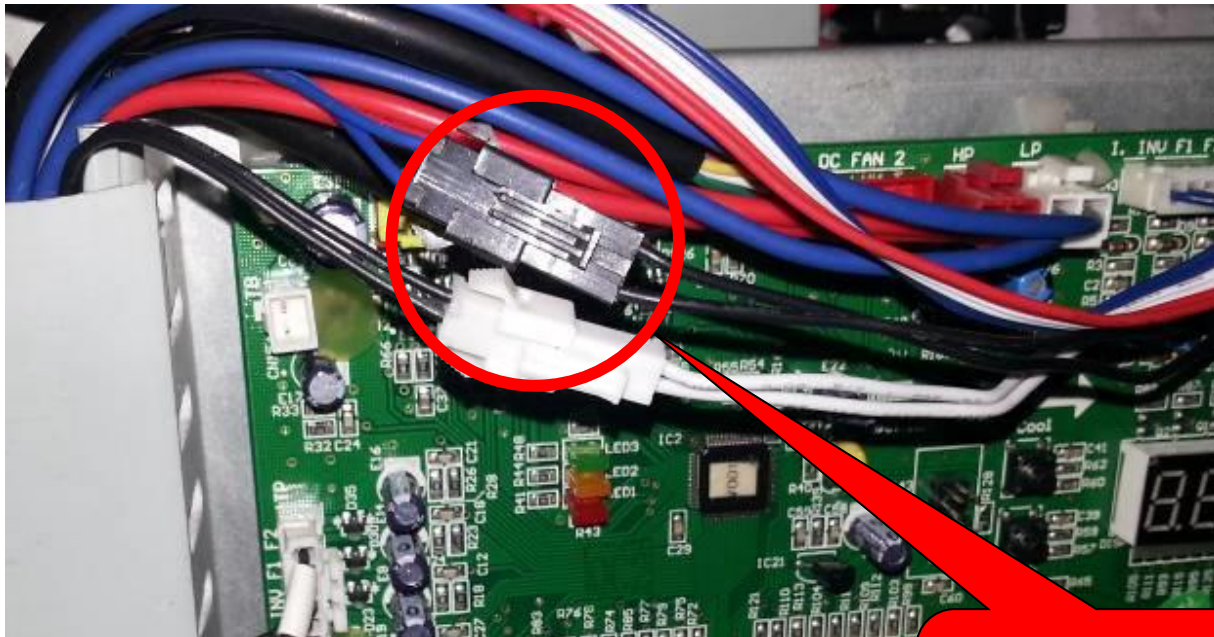

**(Black color) Pull each of the wires to see whether it will come loose.**

**Solutions: If the plug is loose, re-inserted, otherwise go to next step.**

## ***E4: Outdoor ambient temperature sensor(T4) error***

**2. Unplug the ambient temperature sensor plug, measure the resistance of the sensor and see whether there is short circuit or open circuit (outdoor ambient temperature of 0 °C to 40 °C, the resistance range is 13KΩ ~ 2.9KΩ)**

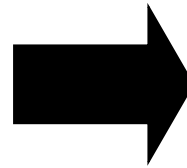

**Solutions: If the resistance measured is 0Ω or OL, replace the ambient temperature sensor; if the sensor is normal, replace the main control board.**

## *E6:Heat exchanger temperature sensor protection*

### *P5: High temperature protection of outdoor condenser*

#### E6,P5: High temp. protection of outdoor condenser

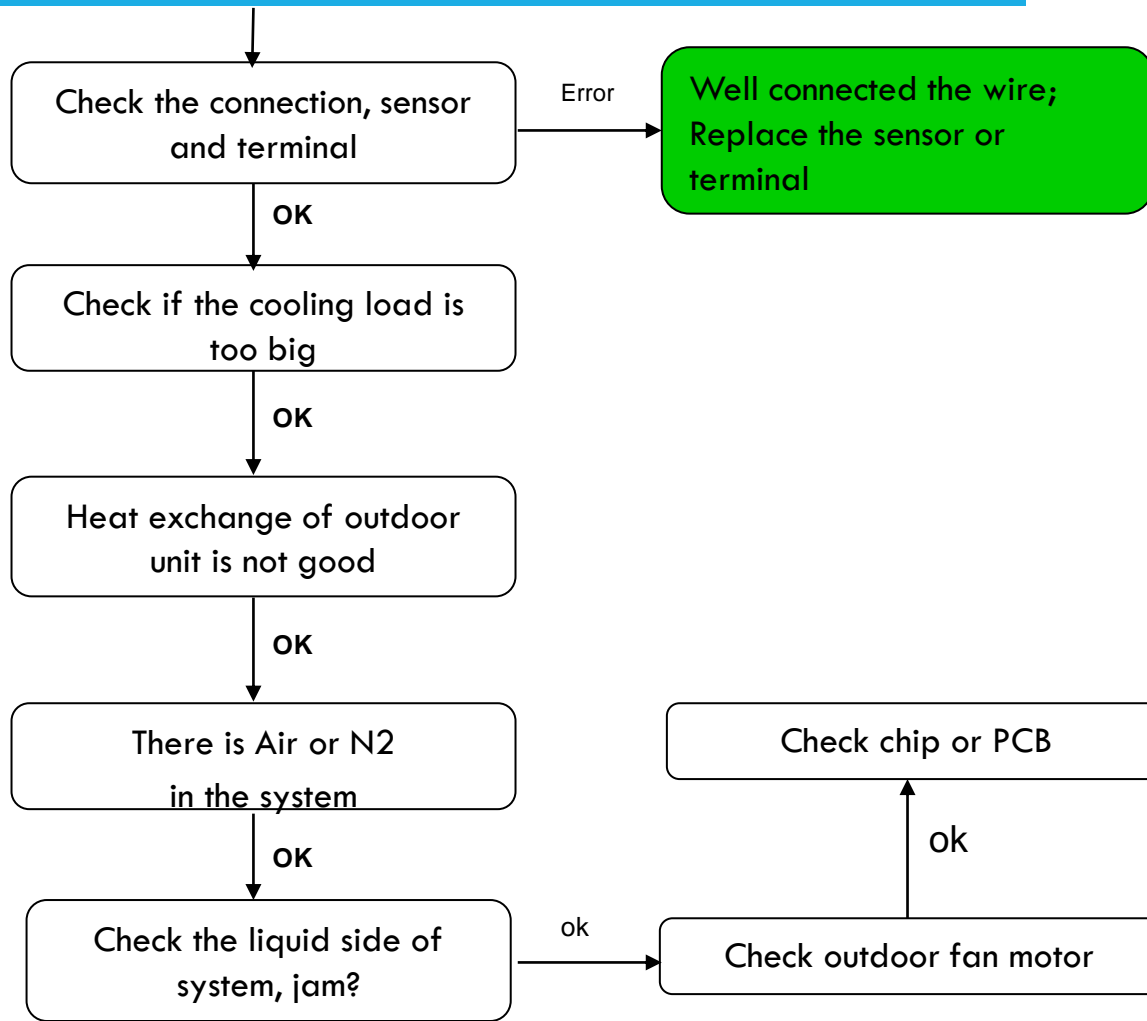

***E6:Heat exchanger temperature sensor protection***

***P5: High temperature protection of outdoor condenser***

**1. Check the outdoor unit's heat exchanger is good or not.**

**Solutions: If heat exchanger is too dirty or something blocks it, then clear the dirty or blocking things; otherwise go to next step.**

***E6:Heat exchanger temperature sensor protection***

***P5: High temperature protection of outdoor condenser***

## **2. Check the sensor connector for loose**



**(White color)Pull each of the wires to see whether it will come loose.**

**Solutions: If the plug is loose, re-inserted, otherwise go to next step.**

## *E6:Heat exchanger temperature sensor protection*

### *P5: High temperature protection of outdoor condenser*

**3. Unplug the outdoor heat exchanger temperature sensor plug, measure the resistance of the sensor and see whether there is short circuit or open circuit (outdoor ambient temperature of  $0^{\circ}\text{C}$  to  $40^{\circ}\text{C}$ , the resistance range is  $13\text{K}\Omega \sim 2.9\text{K}\Omega$ )**

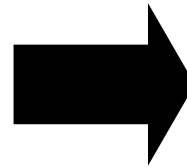

**Solutions: If the resistance measured is  $0\Omega$  or OL, replace the ambient temperature sensor; if the sensor is normal, replace the main control board.**

## ***E8: Outdoor unit address error***

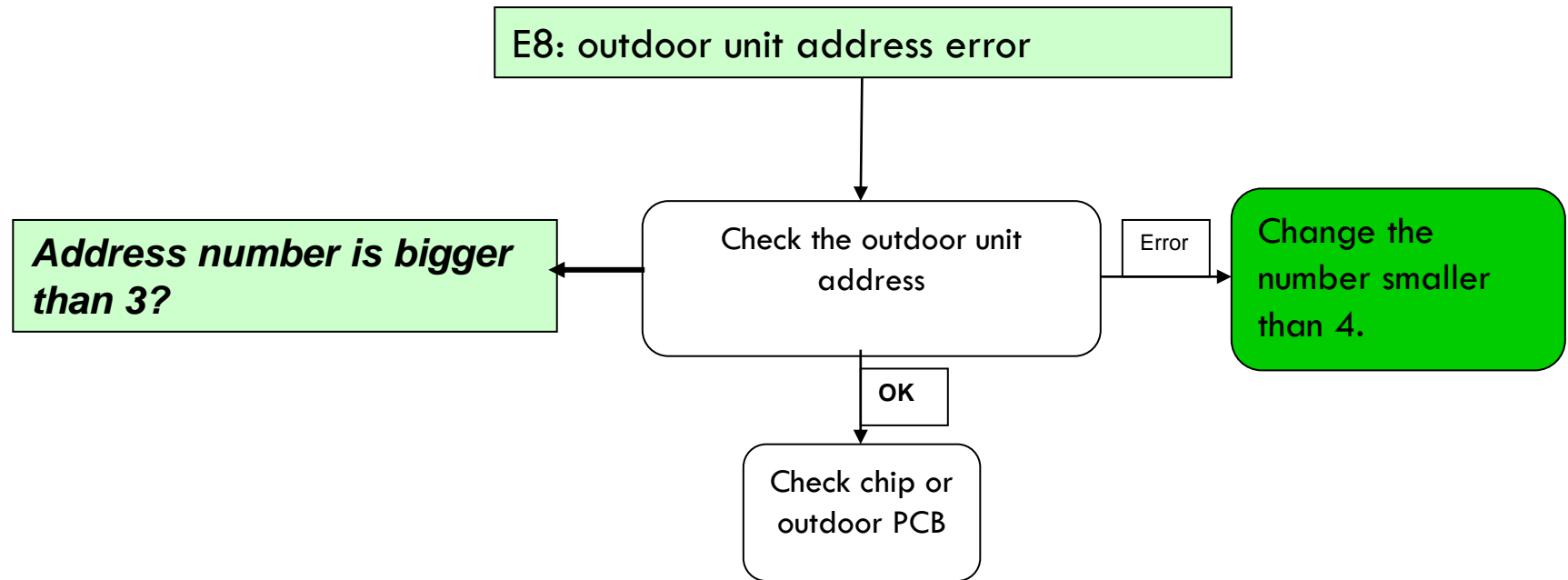

## ***E8: Outdoor unit address error***

**1. Check module address settings for correct (To be effective after re-power on)**

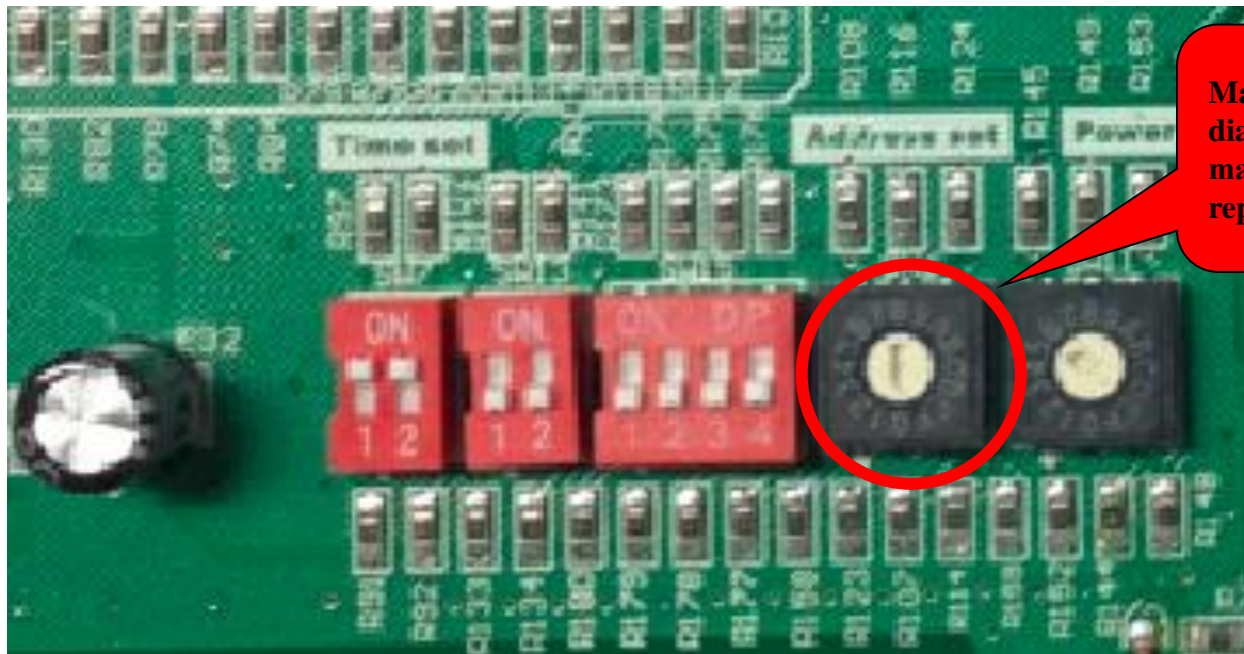

**Master unit dial to 0, slave units dial to other numbers (1,2 or 3), make sure no unit's address is repeat.**

**Solutions: If the address is not set correctly, reset address.**

## ***E8: Outdoor unit address error***

**2. Reset the address (May cause a malfunction if the DIP is not in right place)**

**Solutions: If reset the address can't solve the problem, replace the main control board.**

## ***H0: Communication malfunction between DSP and 0547***

**H0: Communication error between inverter module and 0547 (main chip)**

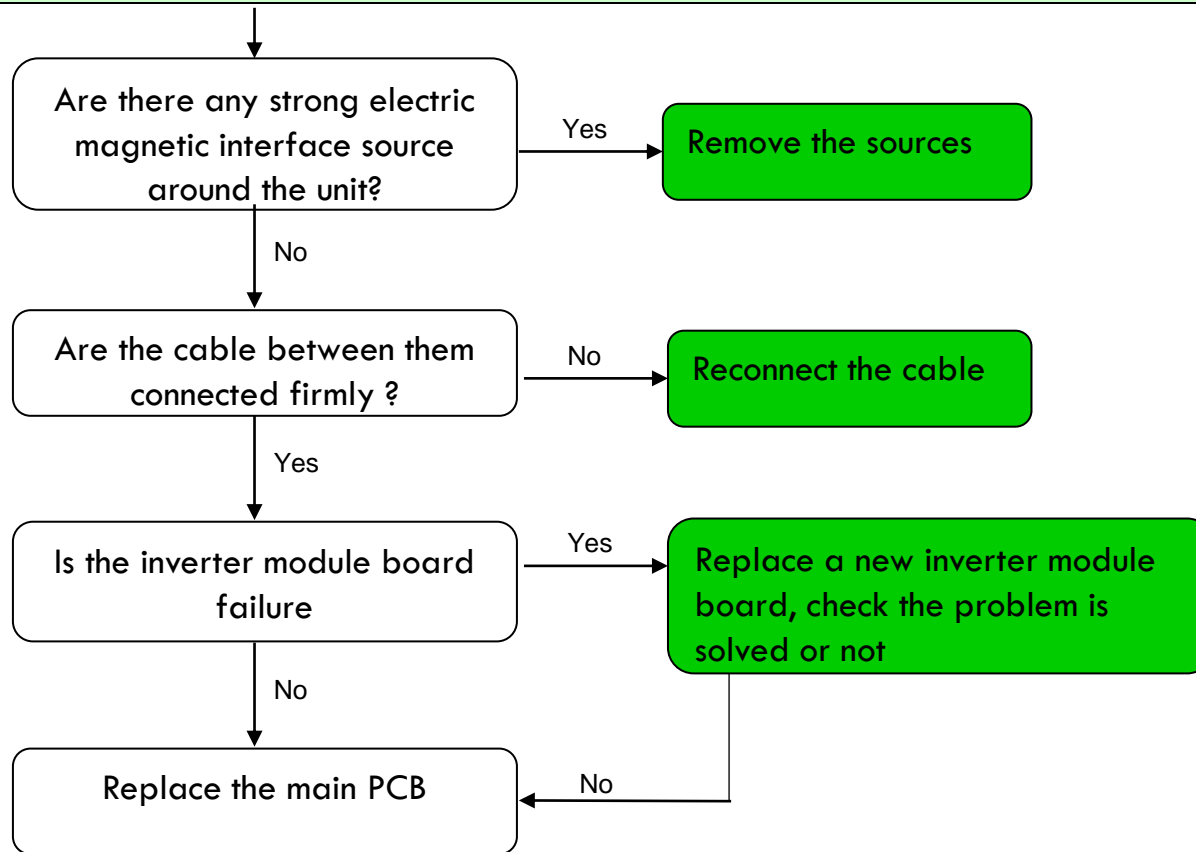

## *H0: Communication malfunction between DSP and 0547*

**1. Check the light on main PCB and inverter module is ON or OFF .**

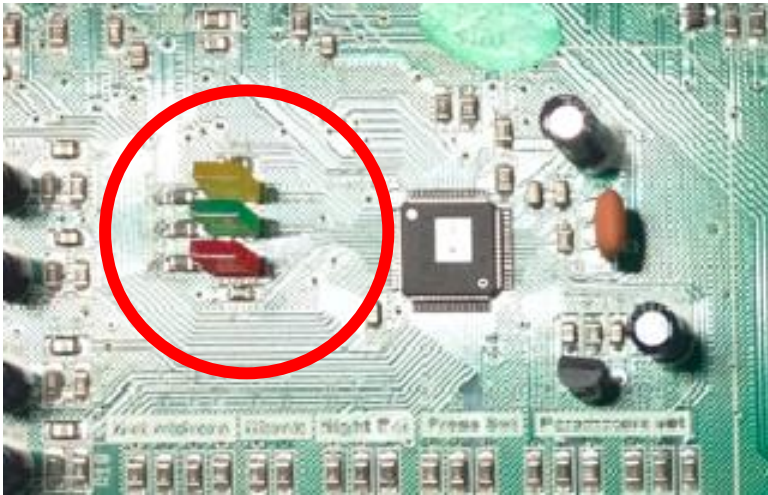

**Solution: If the light is OFF, replace the main PCB or inverter module board, otherwise go to the next step.**

## *H0: Communication malfunction between DSP and 0547*

**2. Check the communication wire between the main control board and module board contact is normal.**

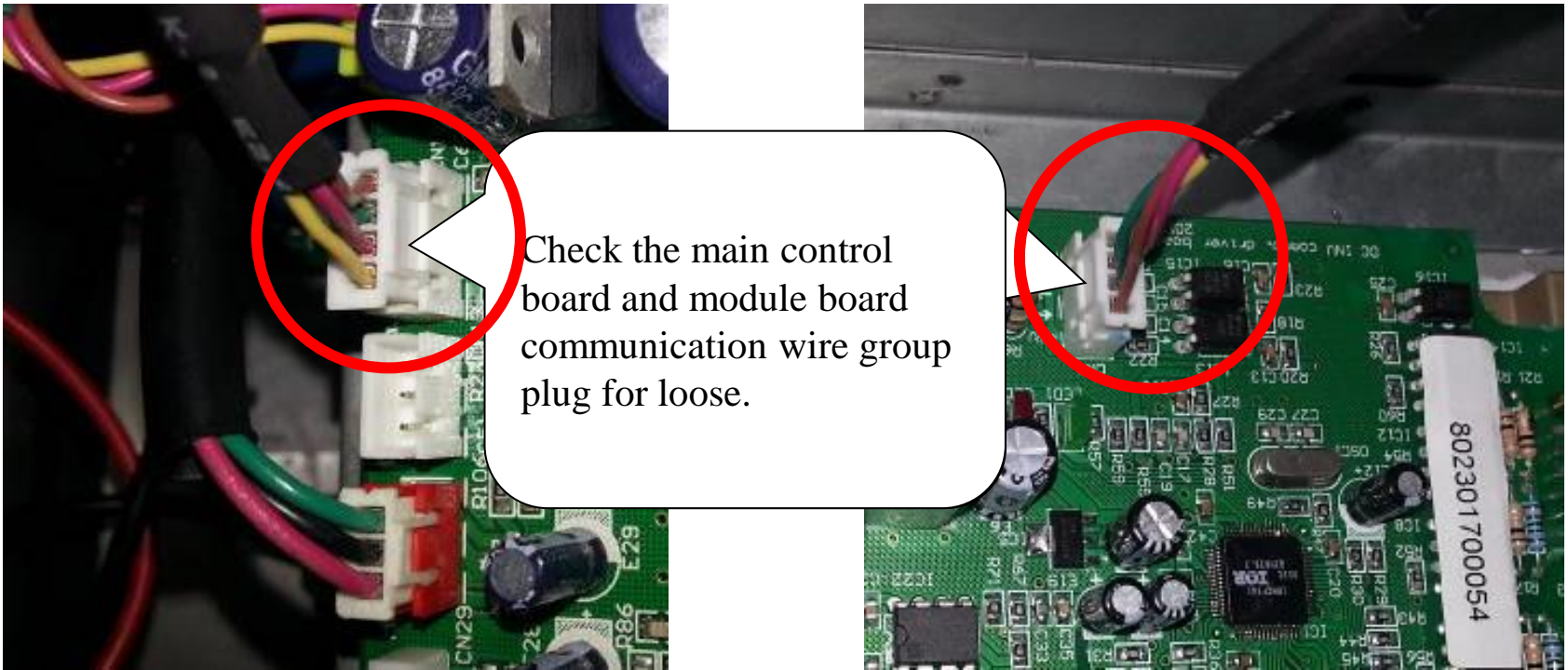

**Solution:** If the plug is loose, re-inserted, otherwise go to the next step.

## *H0: Communication malfunction between DSP and 0547*

**3. Measure the resistance of the communication lines between the main control board and module board, and see whether there is open circuit**



**Solution: If the resistance measured OL, replace the wire group; if displayed  $0\Omega$ , go to the next step**

## *H0: Communication malfunction between DSP and 0547*

### **4. Check the P1, N1 terminal of module board contact firmly or not**

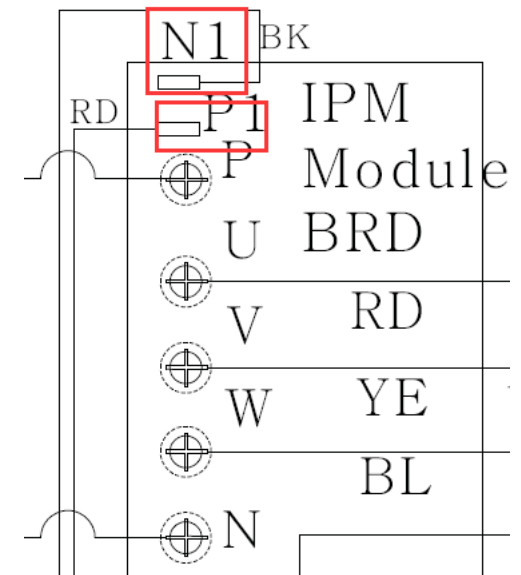

**Solutions:** If the plug contact bad, re-connect; otherwise go to the next step.

***H0: Communication malfunction between DSP and 0547***

**5. Check the CN11 terminal on three phase filter board contact is normal**

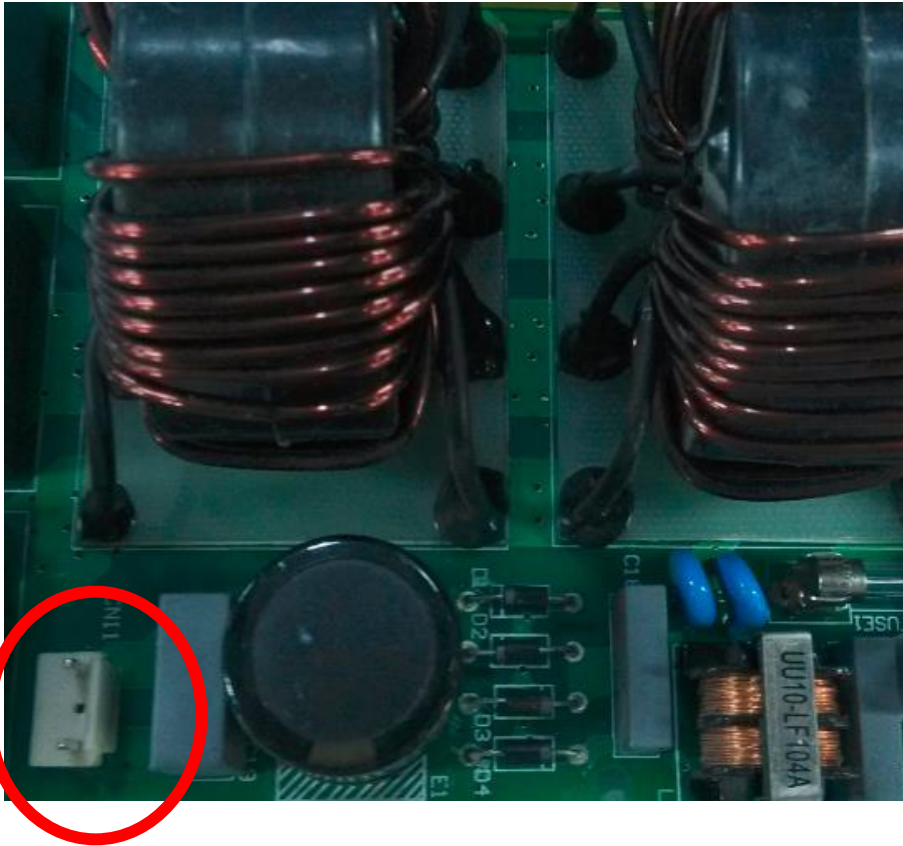

**Solutions: If the plug contact is bad, re-connect; otherwise go to the next step.**

***H0: Communication malfunction between DSP and 0547***

**6. Measure the DC voltage across CN11 with multimeter (normal value is 310V)**

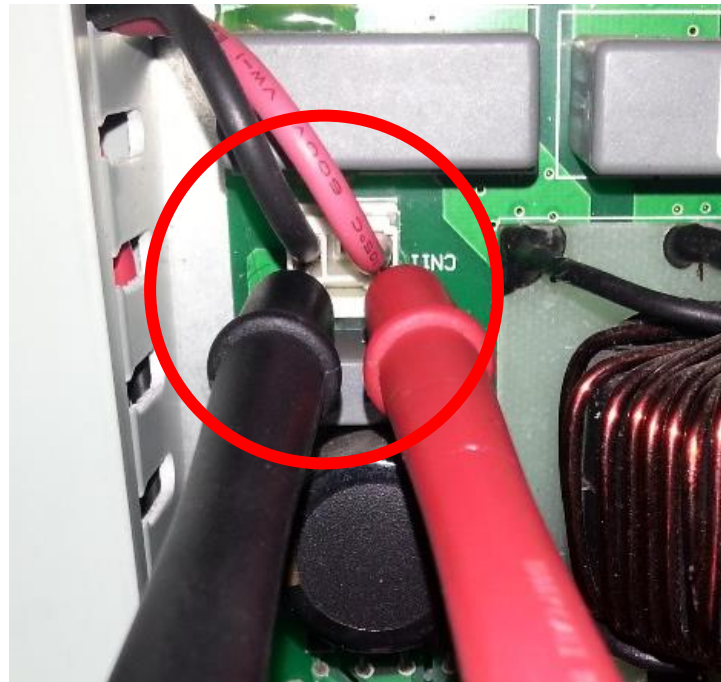

**Solutions: If the voltage is 310V, replace the inverter module board; if the measured voltage is 0V, replace the power filter board.**

***H0: Communication malfunction between DSP and 0547***

**7. If the fault is still the same after doing above steps, still has H0 error, replace the main control board.**

## ***H1: Communication malfunction between chip 0537 and chip 0547***

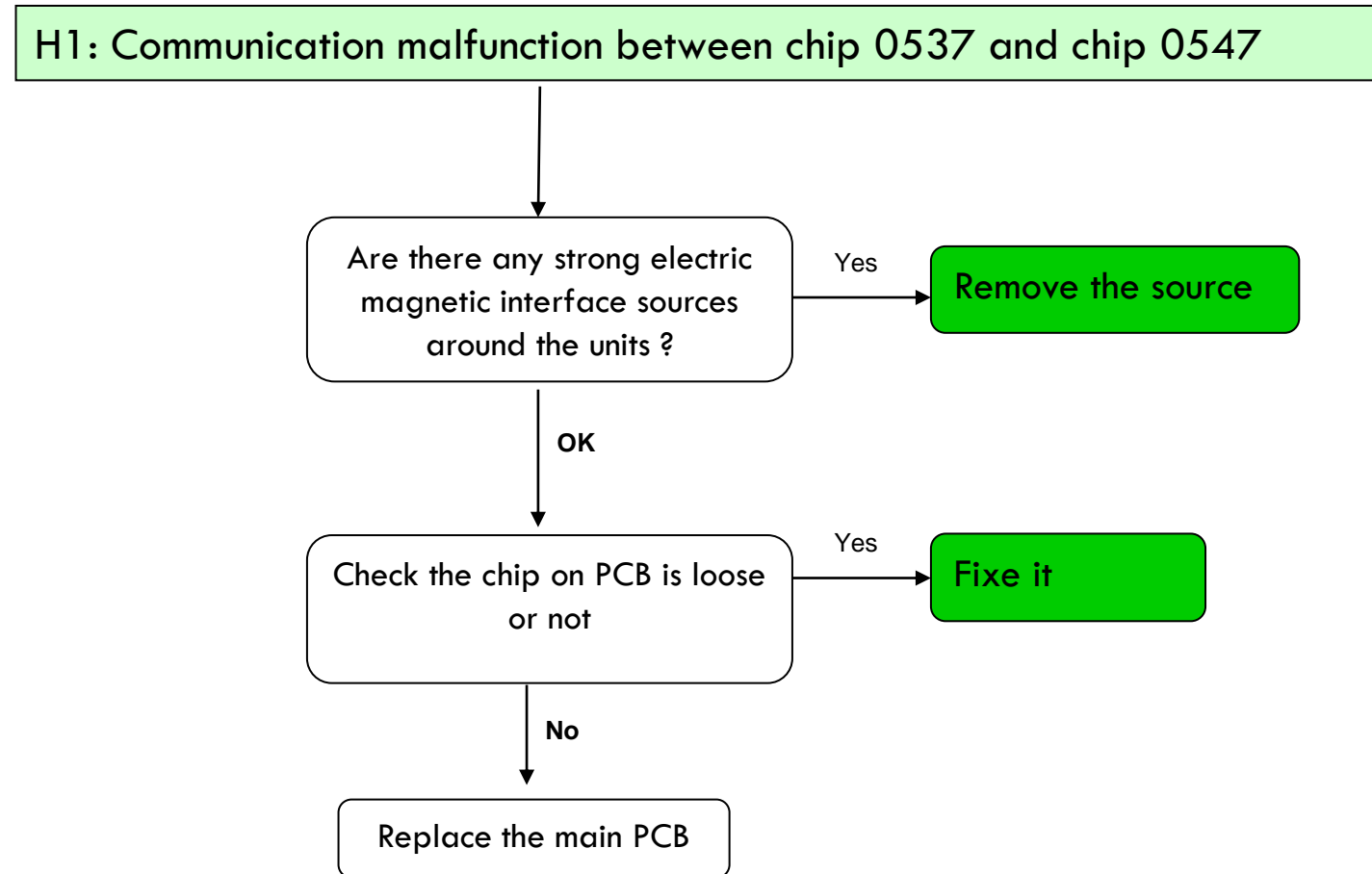

**Solutions: Replace the main control board.**

## H2: Error of reducing in the number of outdoor units

### H2: Error of reducing in the number of outdoor units

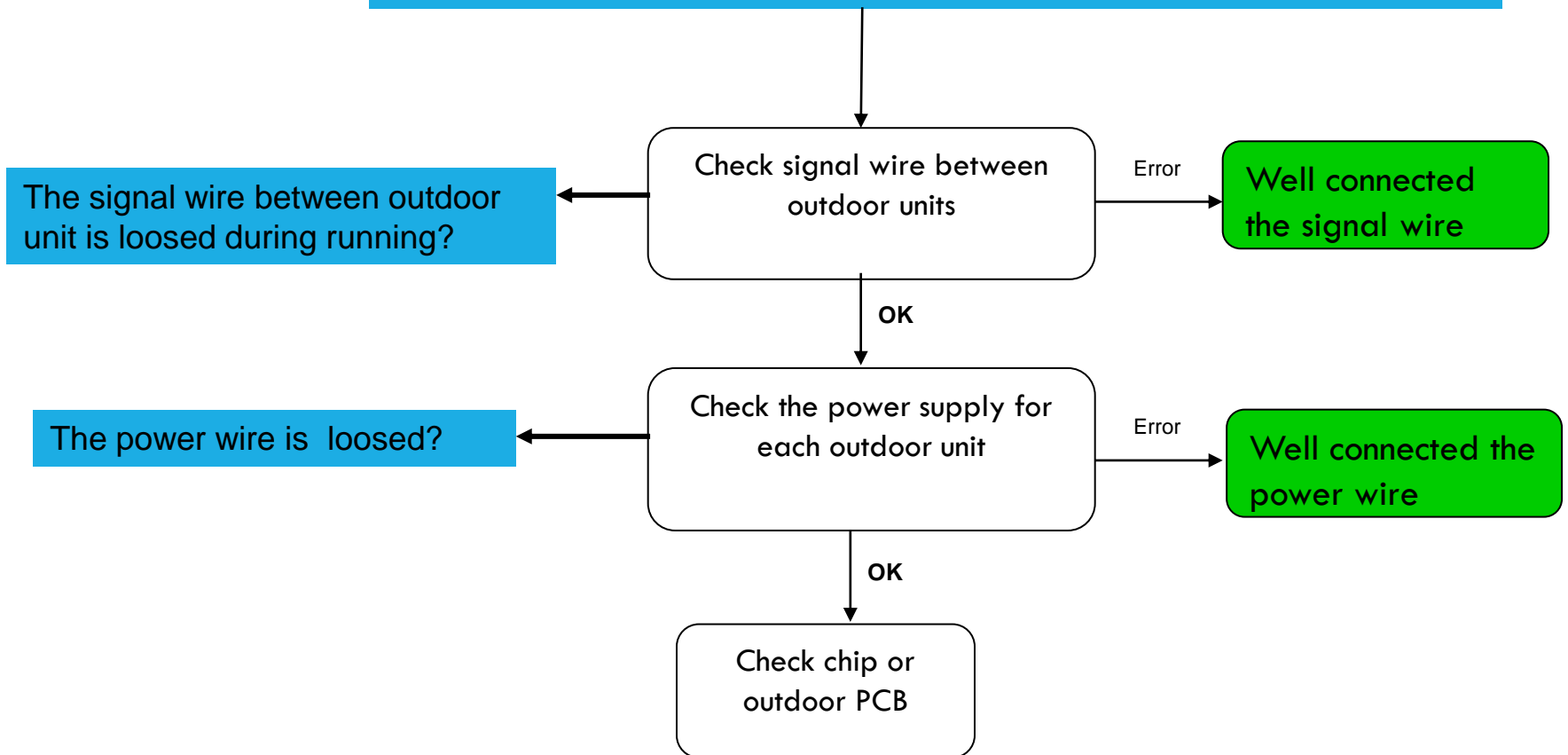

## ***H2: Error of reducing in the number of outdoor units***

- 1. Check the slave unit's communication wire is loose or not.**

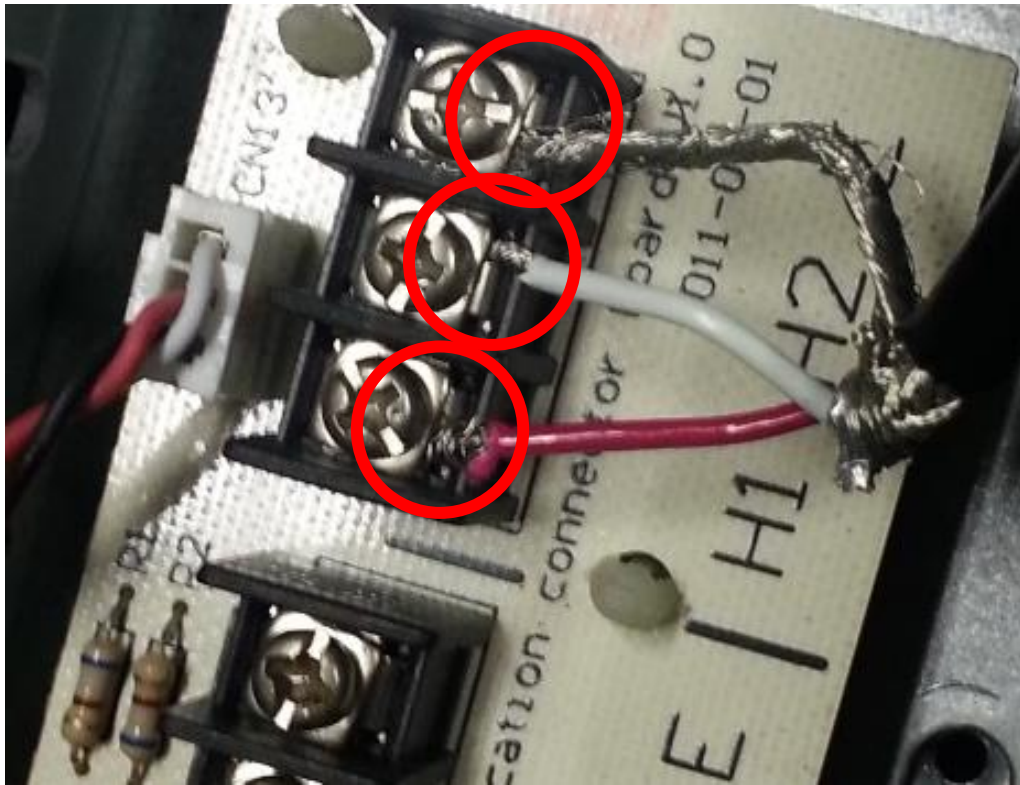

**Solutions: Re-connect well if loose, otherwise go to next step.**

## *H2: Error of reducing in the number of outdoor units*

**2. Check the power lights on slave unit's main control board are ON or not.**

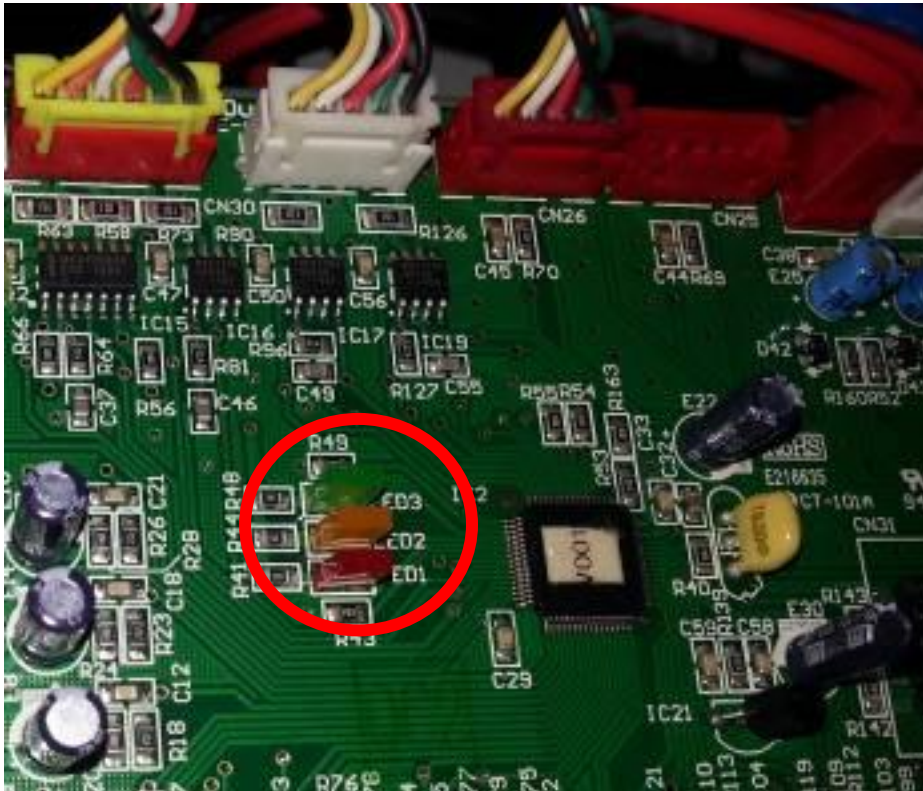

**Solutions: If lights are ON, then replace the main control board; otherwise go to next step.**

## *H2: Error of reducing in the number of outdoor units*

**3. Check the power input terminal is well connected or not.**

**Solutions: If loose, then well connect it; otherwise go to next step.**



## *H2: Error of reducing in the number of outdoor units*

**4. Use multimeter to measure the AC voltage of L1, N terminals on main control board. (normal value should be 220V)**

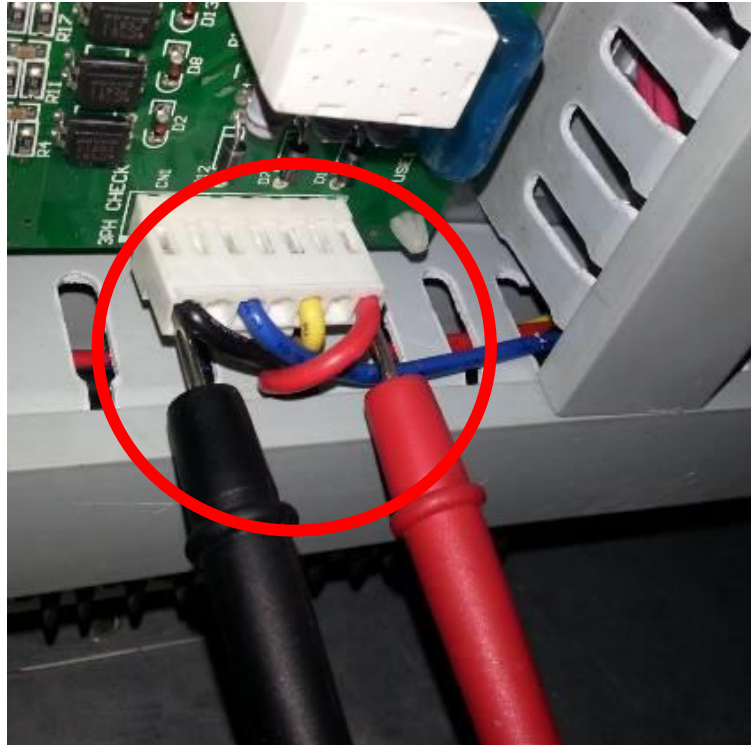

**Solutions: If AC voltage is not 220V, then check the L1 phase of power supply; otherwise go to next step.**

## *H2: Error of reducing in the number of outdoor units*

**5. Use multimeter to measure the AC voltage of transformer's input terminal on main control board. (normal value should be 220V)**



**Solutions: If AC voltage is not 220V, then replace the fuse; otherwise go to next step.**

## *H2: Error of reducing in the number of outdoor units*

**6. Use multimeter to measure the AC voltage of transformer's output terminal on main control board. (normal value: between Yellows 11V, browns 14.5V)**



**Solutions: If AC voltage is not correct, then replace the transformer; otherwise replace the main control board.**

***H3: Error of increasing in the number of outdoor units***

**H3 usually cause by outdoor units have different power supply.**

**Solutions: system will automatically restart.**

## P2: Low-pressure Protection

H5: There are 3 times P2 protection in 30 minutes.

**Display H5, outdoor unit  
Must Repeat power on.**

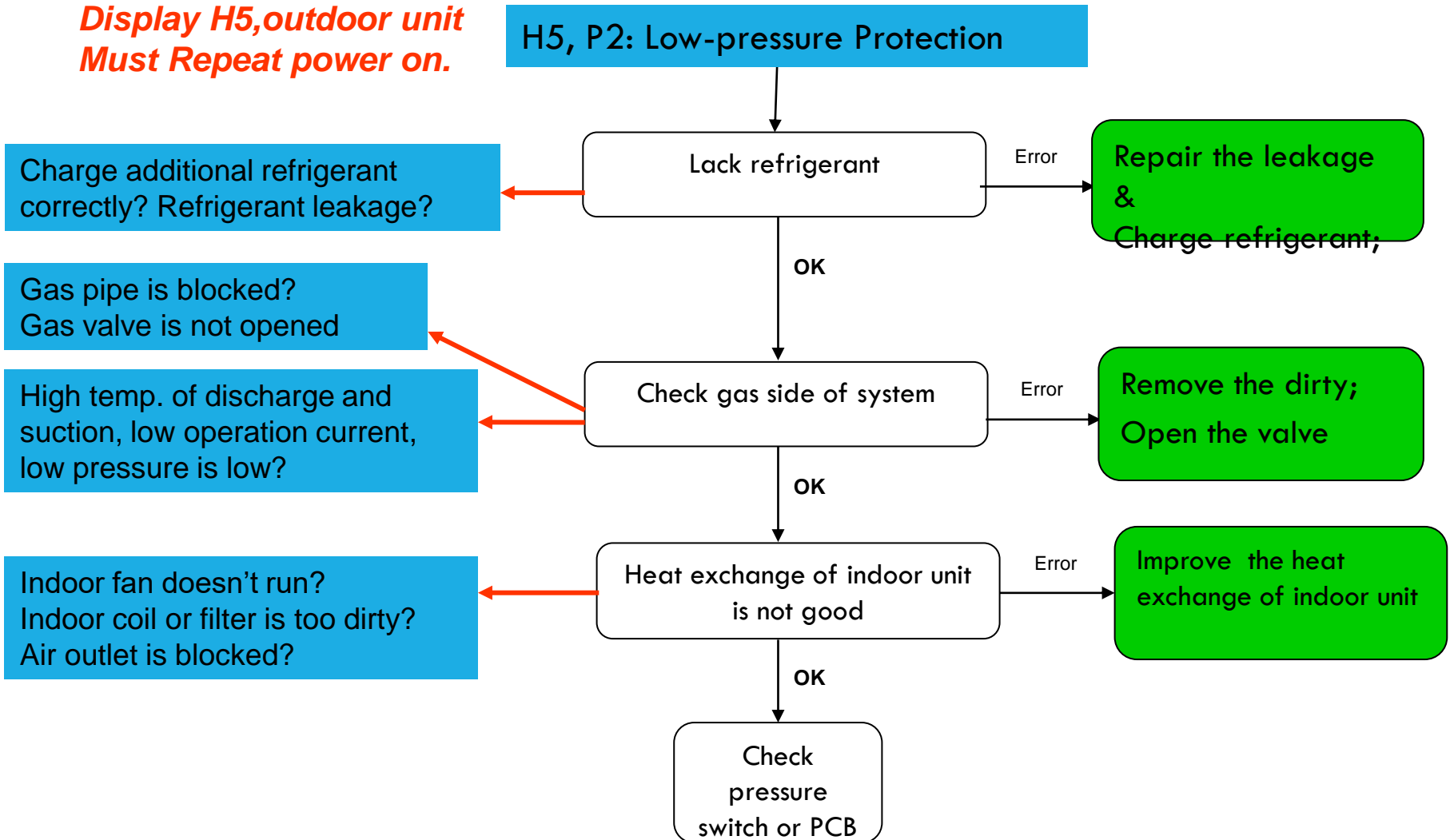

## ***P2: Low-pressure Protection***

***H5: There are 3 times P2 protection in 30 minutes.***

**1. Use pressure gauge to check the low pressure when system is running. (Normally low pressure should be 0.7-0.9MPa, when pressure is lower than 0.05MPa, system will be under protection and stop, when it is higher than 0.15Mpa, it will recovery))**



**Solution: If pressure is down to 0.05MPa then go to step 2, If pressure is normal, then go to step 3.**

## ***P2: Low-pressure Protection***

***H5: There are 3 times P2 protection in 30 minutes.***

**2. Check the refrigerant leakage points of system then recharge refrigerant; Check the low pressure side is blocked.**

**Some phenomenon of lack of refrigerant and block:**

- Top temp. and discharge temp. of all compressors are very high;**
- Discharge pressure and suction pressure are very low;**
- Operation current is low;**
- Suction pipe may be frosting.**

## ***P2: Low-pressure Protection***

***H5: There are 3 times P2 protection in 30 minutes.***

**3. Check connection between low pressure switch and main control board is fasten or not.**

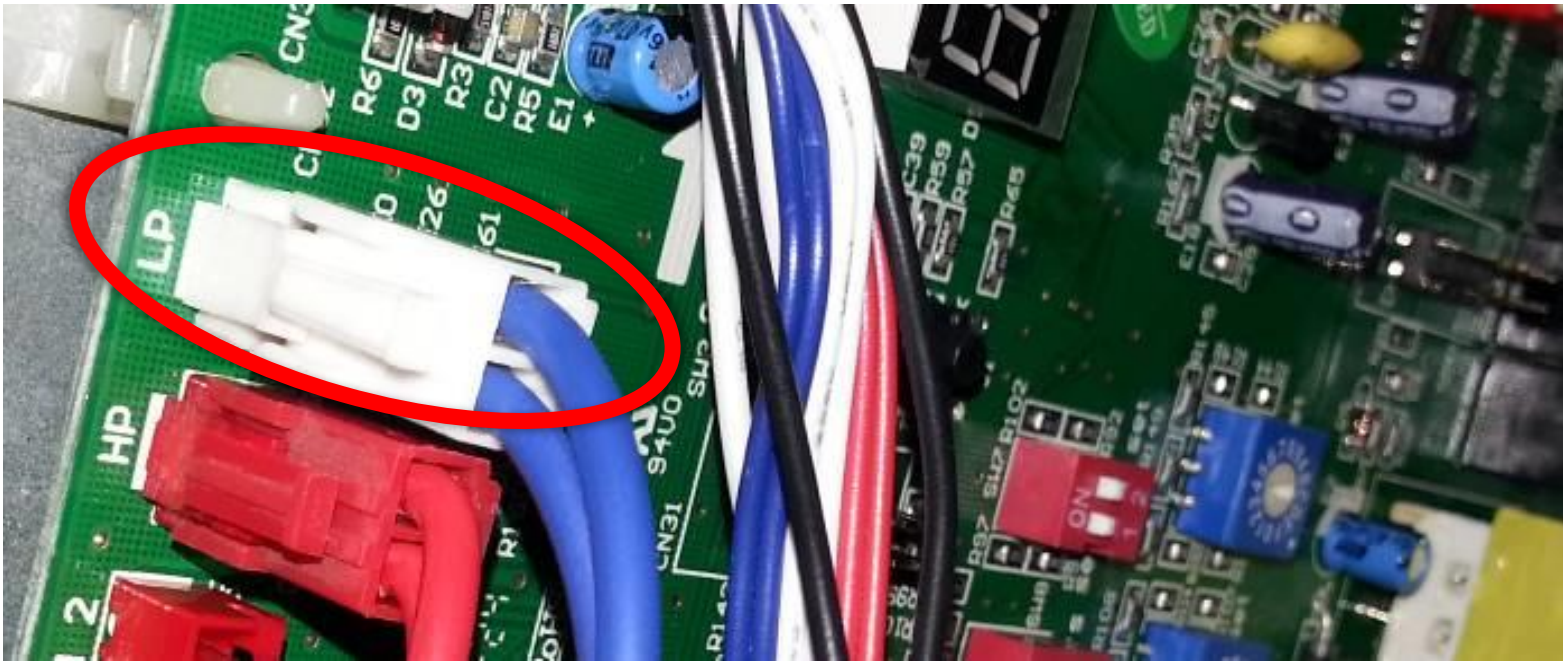

**Solution: If loose, re-connect them, otherwise go to next step.**

## ***P2: Low-pressure Protection***

***H5: There are 3 times P2 protection in 30 minutes.***

**4. Pull out the low pressure switch and measure its resistance (normal 0)**

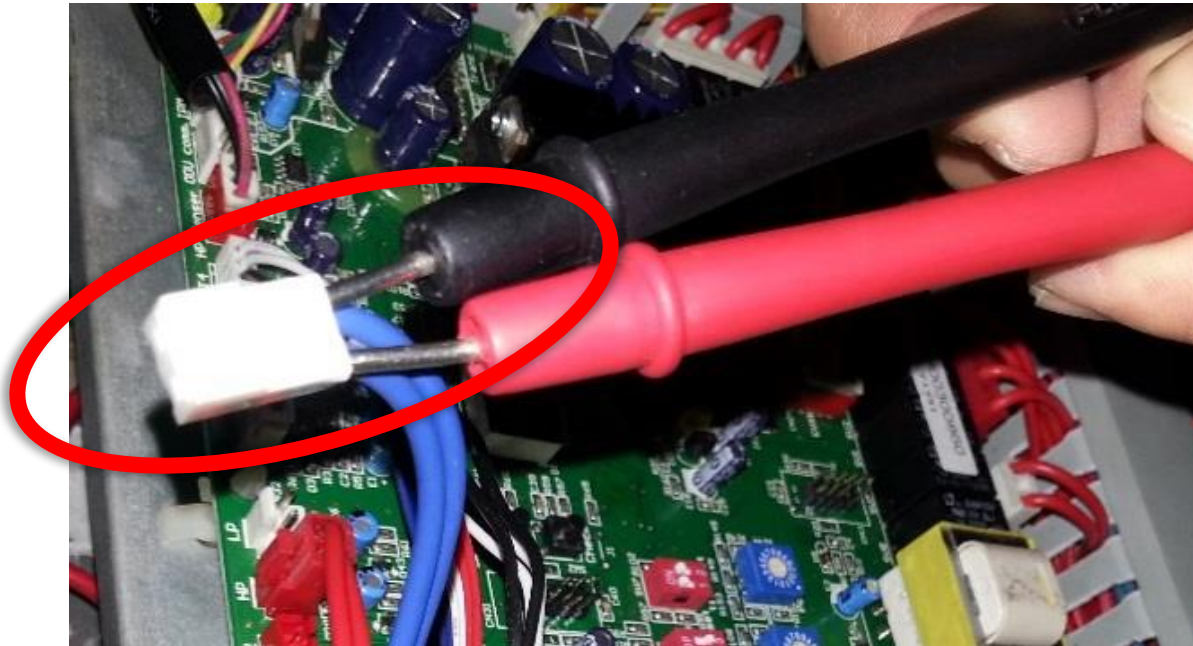

**Solution: if resistance is normal, then replace the main control board; otherwise change the low pressure switch.**

## P4: High discharge temperature

H6: There are 3 times P4 protection in 100 minutes

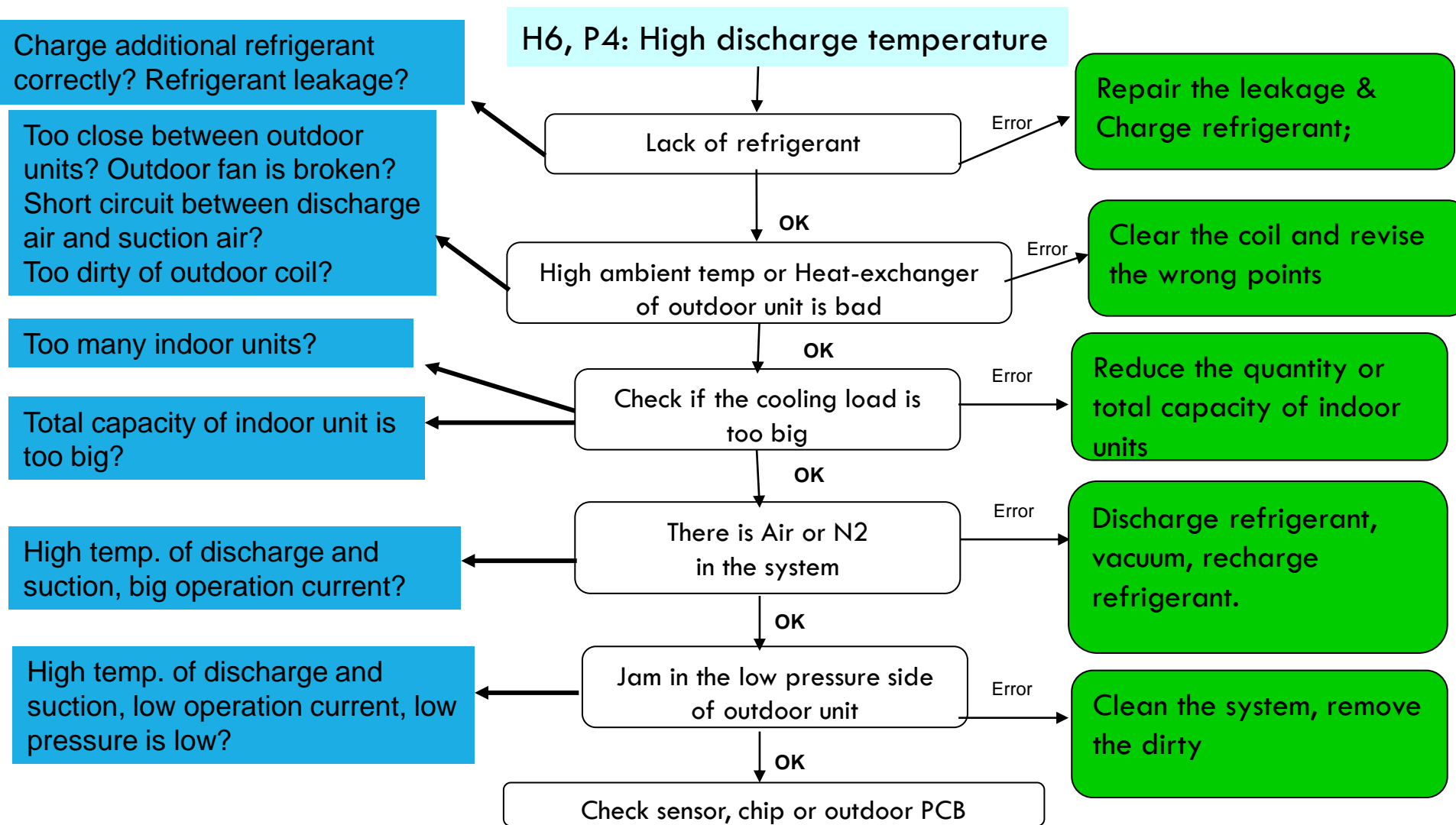

***P4: High discharge temperature***

***H6: There are 3 times P4 protection in 100 minutes***

**1. Check the low pressure (normally should be 0.7-0.9MPa)**



**Solution: If pressure is too low, then refill the refrigerant and go to step 2. If pressure is normal then go to step 3.**

***P4: High discharge temperature***

***H6: There are 3 times P4 protection in 100 minutes***

**2. Check SV2 is good or not (check its output terminals voltage, normally should be 220V AC)**

**Solution: if SV2 output voltage is 0, then replace the main control board, other wise replace the SV2.**

***P4: High discharge temperature***

***H6: There are 3 times P4 protection in 100 minutes***

**3. Check the temperature sensor is good or not. (50K $\Omega$ /25 $^{\circ}$ C)**

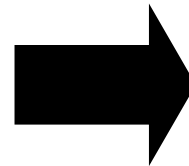

**Solution: if temperature sensor is malfunction, replace it. Other wise replace the main control board.**

## H7: Indoor unit quantities decreasing malfunction over 3 minutes

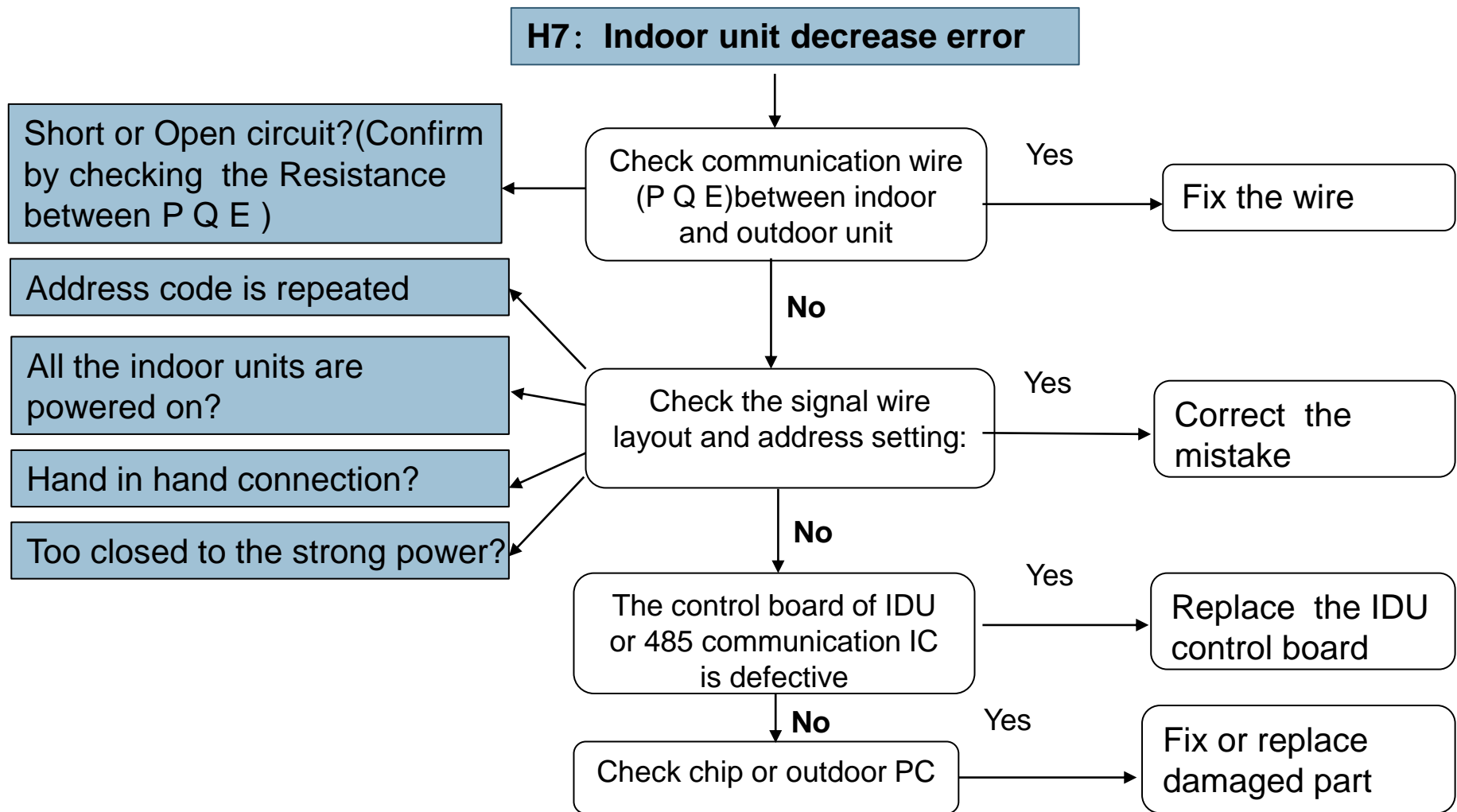

## ***H7: Indoor unit quantities decreasing malfunction over 3 minutes***

**1. Check the online indoor units quantity ( by enquiry button on outdoor main control board) and real indoor units quantity. For example, 20 indoor units in a system, but system finds only 15 indoor units online, then 5 indoor units are missing then check the No.16 indoor unit's wiring for loose.**

**Solution: if loose, re-connect it. Otherwise go to next step.**

**2. Check all indoor units to find out the units lose power.**

**Solution: if some indoor units lose power, re-connect them. Otherwise go to next step.**

**3. Check all indoor units' address one by one for the repeat address.**

**Solution: If some addresses are repeat, use address setting controller to set new addresses(make sure no repeat) for them. Otherwise go to next step.**

**4, Check all indoor units for communication error (indoor unit or wired controller display E1/Timer light flashes).**

**Solution: If yes, solve the problem. Otherwise go to next step.**

**5, All the communication wire must be 2-core shielded wire.**

## P9: inverter fan module protection

H9: There are 3 times P9 protection in 30 minutes

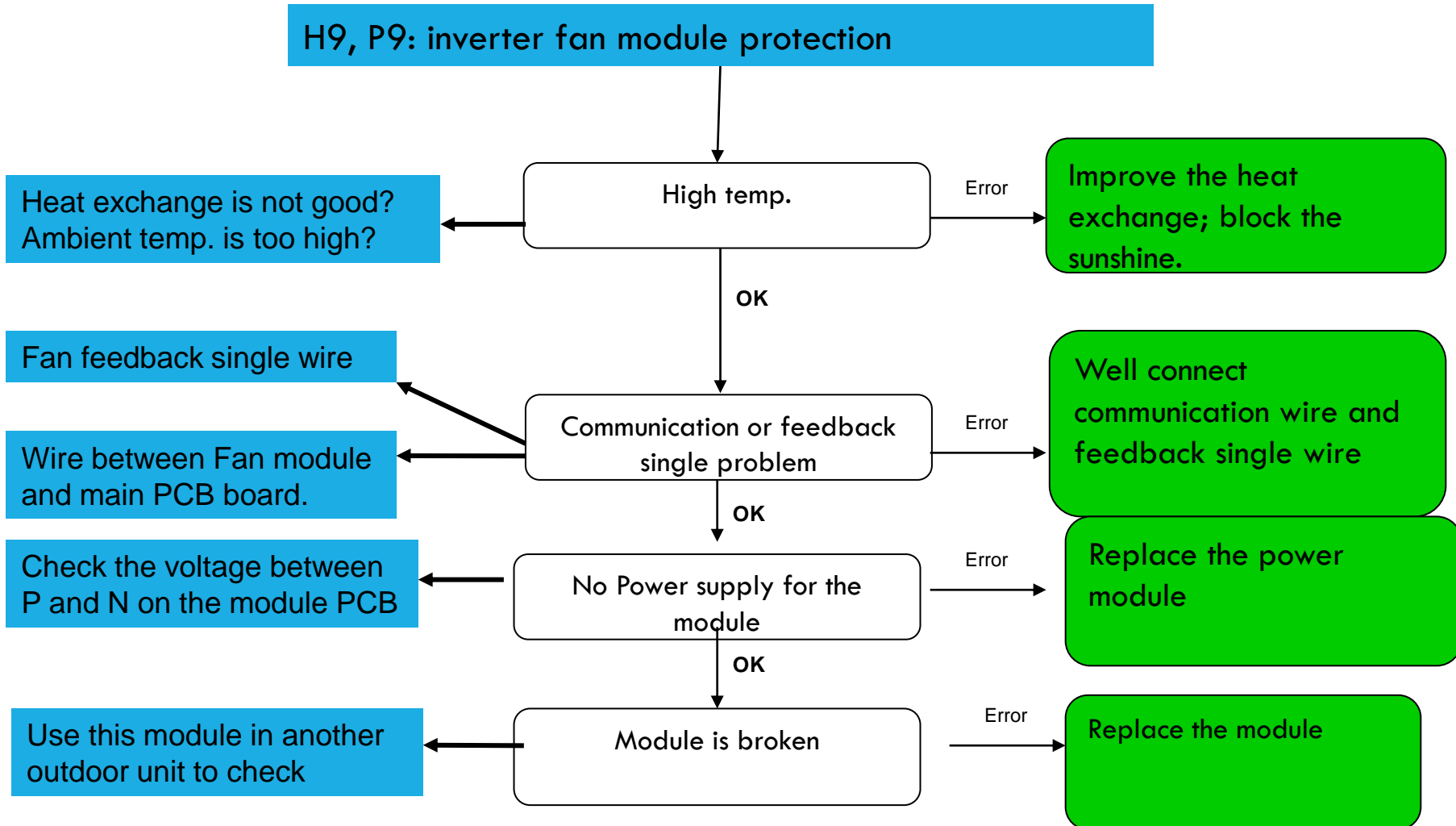

***P9: inverter fan module protection***

***H9: There are 3 times P9 protection in 30 minutes***

**1. Check the inverter fan module board's light is ON or OFF.**

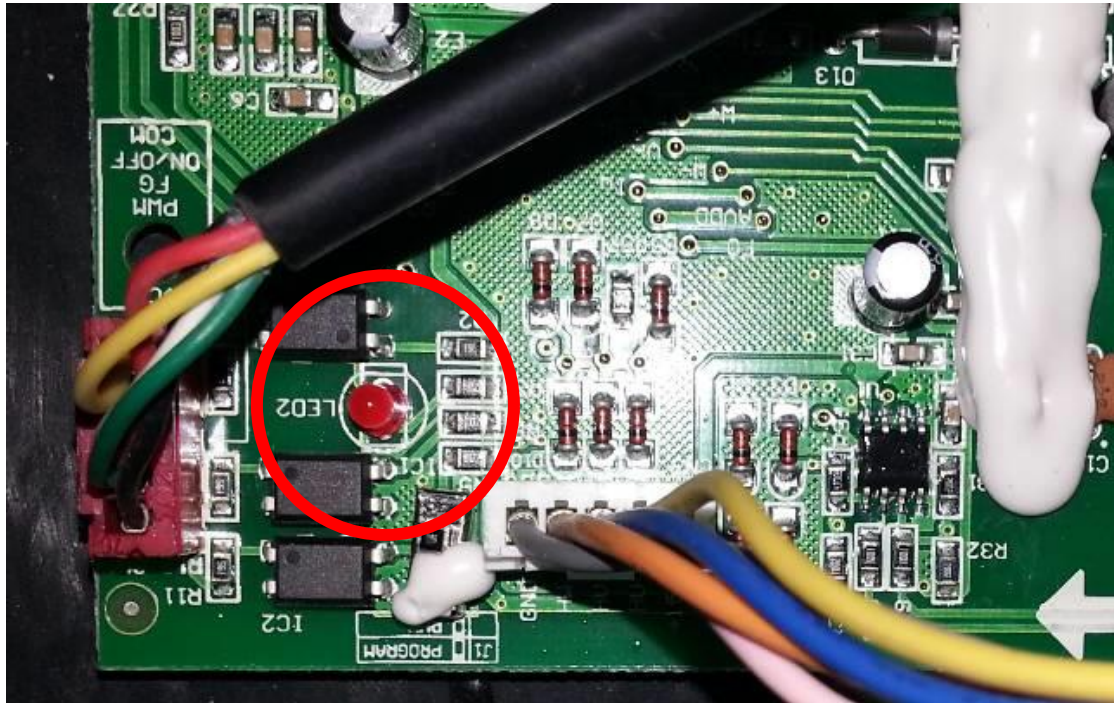

**Solution: If it is OFF, replace the fan module board, Otherwise go to next step.**

***P9: inverter fan module protection***

***H9: There are 3 times P9 protection in 30 minutes***

**2. Check the connection between fan module board and main PCB is loose, Check the connector between fan module and fan motor is loose**

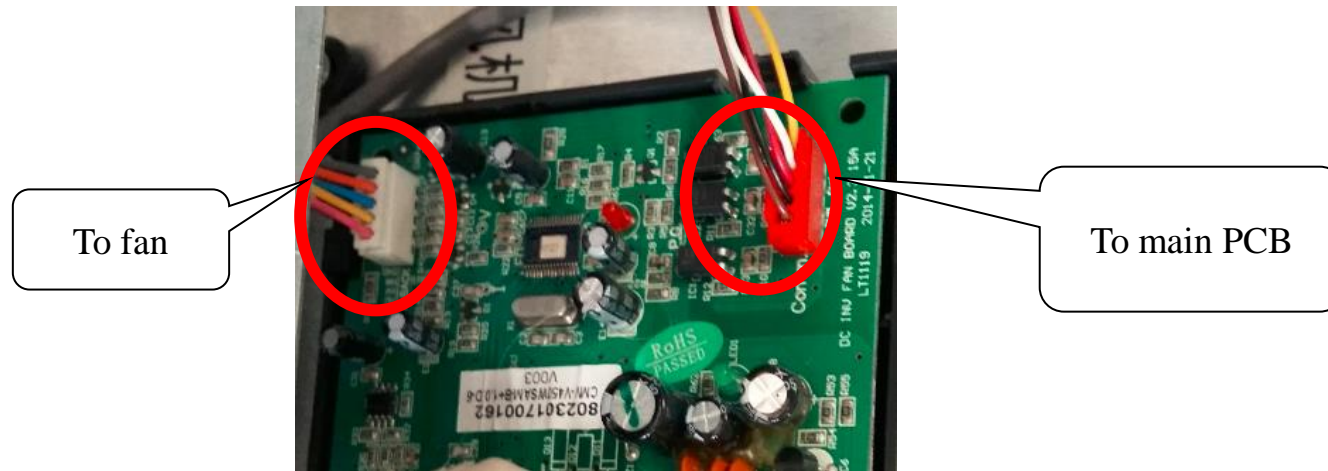

**Solution: If the plug is loose, reconnect it, otherwise go to next step**

***P9: inverter fan module protection***

***H9: There are 3 times P9 protection in 30 minutes***

**3. Check the P, N terminals voltage. ( normal value 310V DC)**

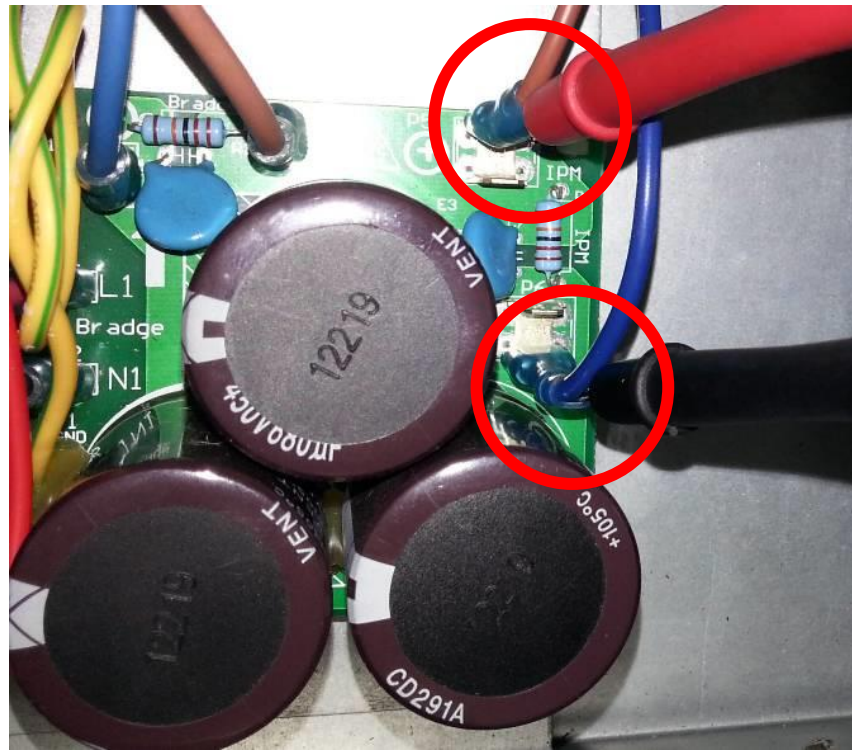

**Solution: replace the board if voltage is 0V. Otherwise go to next step.**

## ***P9: inverter fan module protection***

***H9: There are 3 times P9 protection in 30 minutes***

**4. Use multimeter to check the voltage of HU, HV, HW in CN3 of fan module board. Normal value 2-4V DC, when fan is rotating manually, 0V DC, means fan motor damaged.**

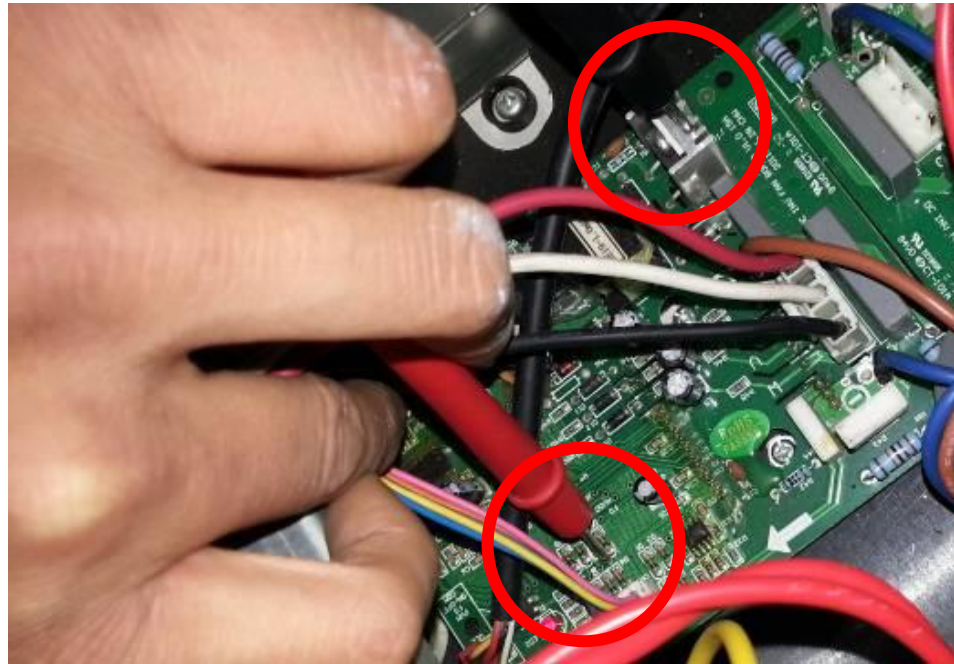
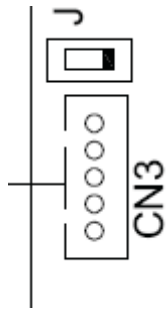

**Solution: If motor damaged, then replace the motor. Otherwise go to next step.**

***P9: inverter fan module protection***

***H9: There are 3 times P9 protection in 30 minutes***

**5. Use multimeter to measure the voltage between ground and middle pin (third pin) of CN26 and CN25. Normal value 2-4V DC, when fan is rotating manually, 0V DC means fan module board damaged.**

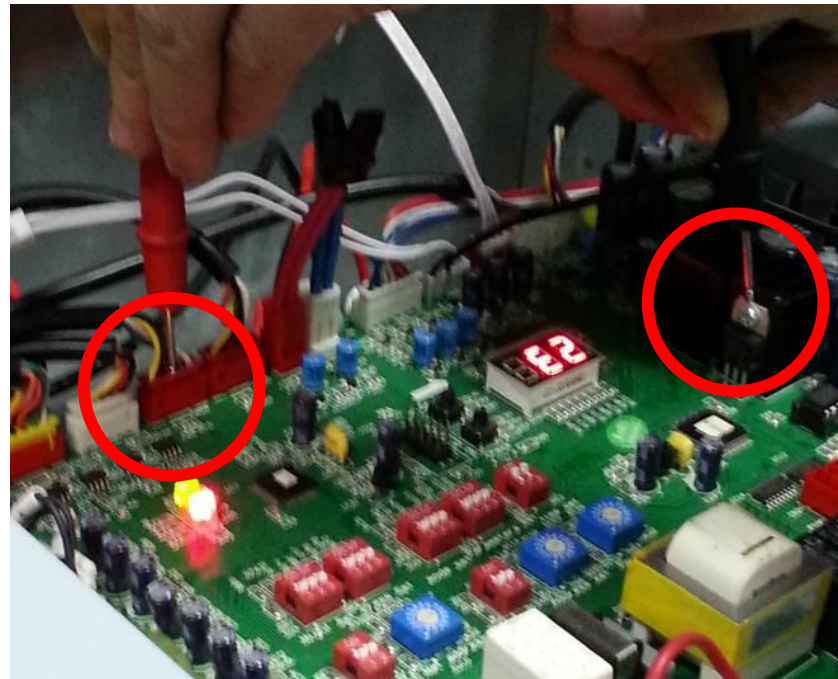
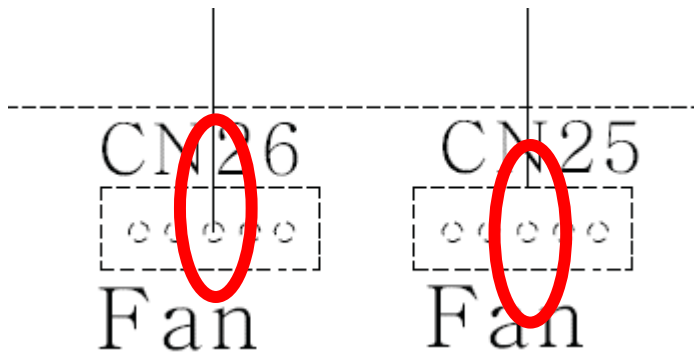

**Solution: If fan module board damaged, then replace it. Otherwise replace main control board.**

## P1: High-pressure Protection

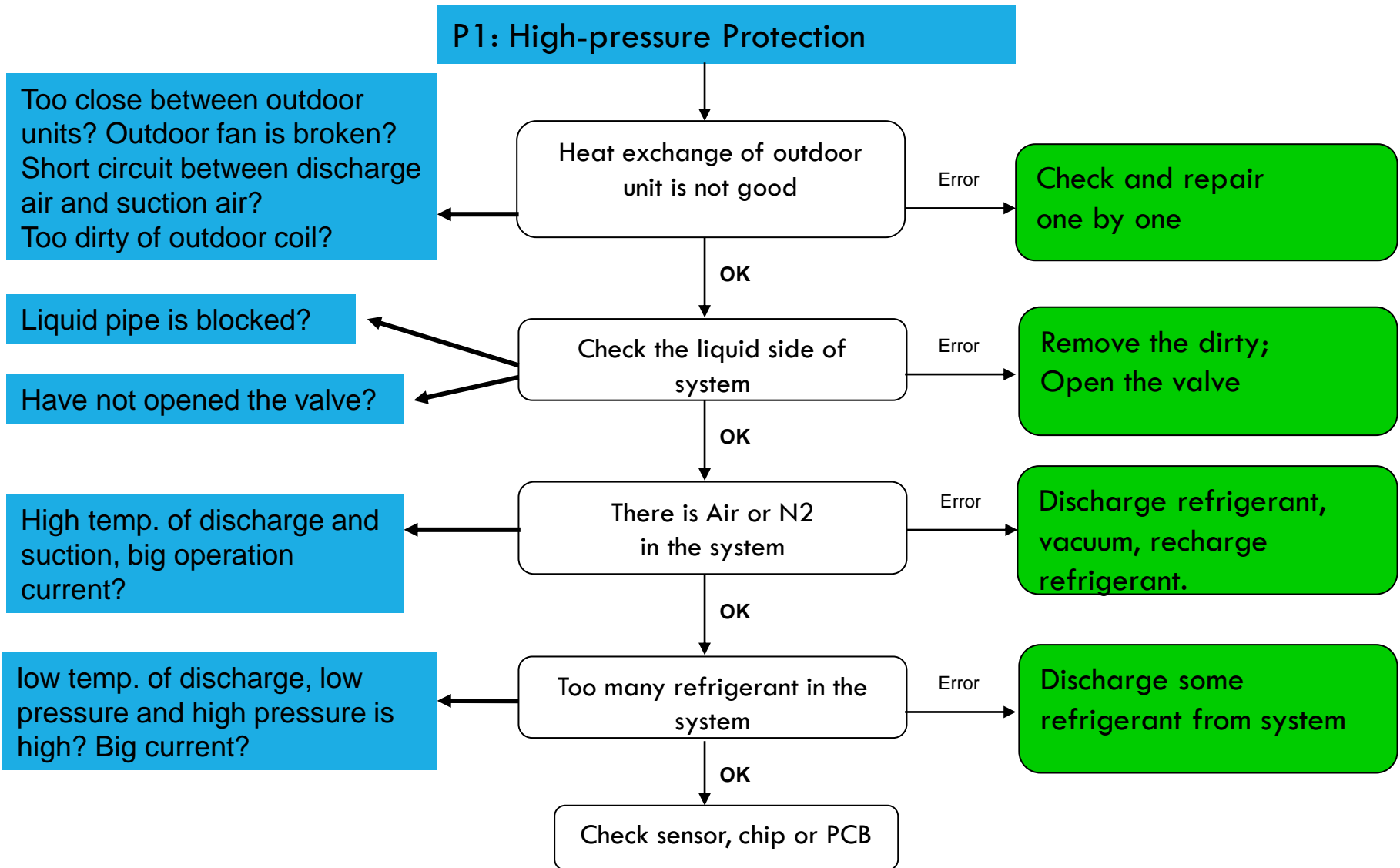

## ***P1: High-pressure Protection***

**1. Check the outdoor unit's heat exchanger is good or not.**

**Solutions: If heat exchanger is too dirty or something blocks it, then clear the dirty or blocking things; otherwise go to next step.**

## ***P1: High-pressure Protection***

**2. Check connection between high pressure switch and main control board is fasten or not.**



**Solution: If loose, re-connect them, otherwise go to next step.**

## *P1: High-pressure Protection*

**3. Pull out the high pressure switch and measure its resistance (normal 0)**



**Solution: if resistance is normal, then replace the main control board; otherwise change the high pressure switch.**

**P3: current protection of DC inverter compressor**

**P7: current protection of fixed speed compressor**

**P3,P7: current protection of compressor**

Heat exchange of outdoor unit is not good

OK

Check the liquid side of system

OK

There is Air or N2 in the system

OK

Too much refrigerant in the system

OK

Compressor or strong power part is abnormal

Error

Replace the compressor or other damaged part.

Short circuit of strong power part?

Compressor malfunction?  
The normal resistance between any two terminals of compressor is 1~3Ω

Check chip or PCB

OK

***P3: current protection of DC inverter compressor***

***P7: current protection of fixed speed compressor***

- 1. Check outdoor unit heat exchanger is good or not, it should be in good ventilation condition;**
- 2. Charge too much refrigerant, N2 or air inside the system.**

**Usually cause by bad outdoor unit heat exchanging condition.**

**When the inverter compressor current is higher than 12A , it will appear.**

## P6: Inverter module protection

H4: There are 3 times P6 protection in 30 minutes.

**Display H4, outdoor unit  
Must Repeat power on.**

H4, P6: Inverter module protection

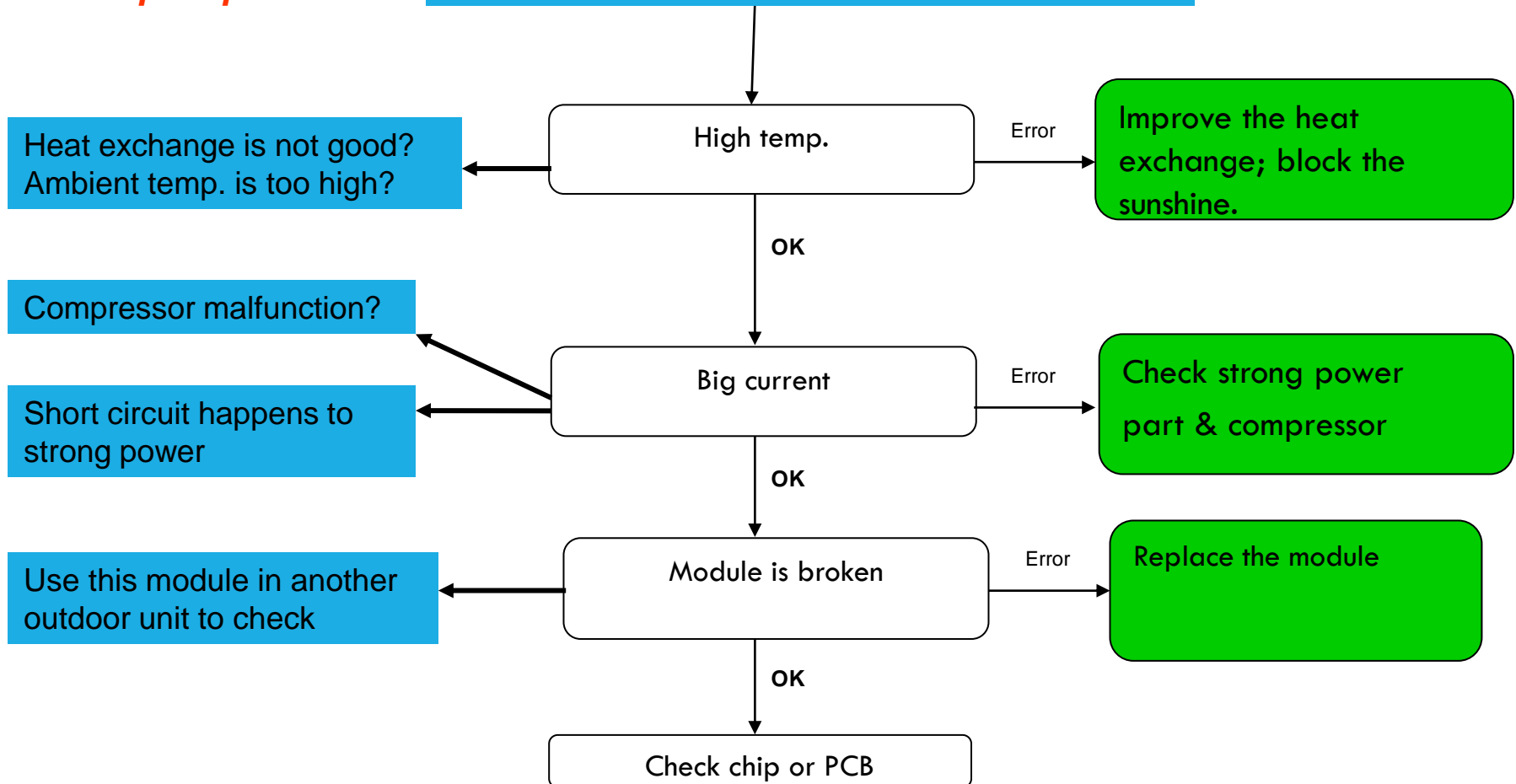

## Outdoor unit error code

Code	Malfunction or protection	remark
L0	Inverter compressor malfunction	After P6 displaying for 60s, they will display
L1	DC generatrix low voltage protection	
L2	DC generatrix high voltage protection	
L3	reserved	
L4	MCE malfunction/simultaneously/cycle loop	
L5	Zero speed protection	
L6	reserved	
L7	Wrong phase protection	
L8	Speed difference >15Hz protection between the front and the back clock	
L9	Speed difference >15Hz protection between the real and the setting speed	

## ***P6: Inverter module protection***

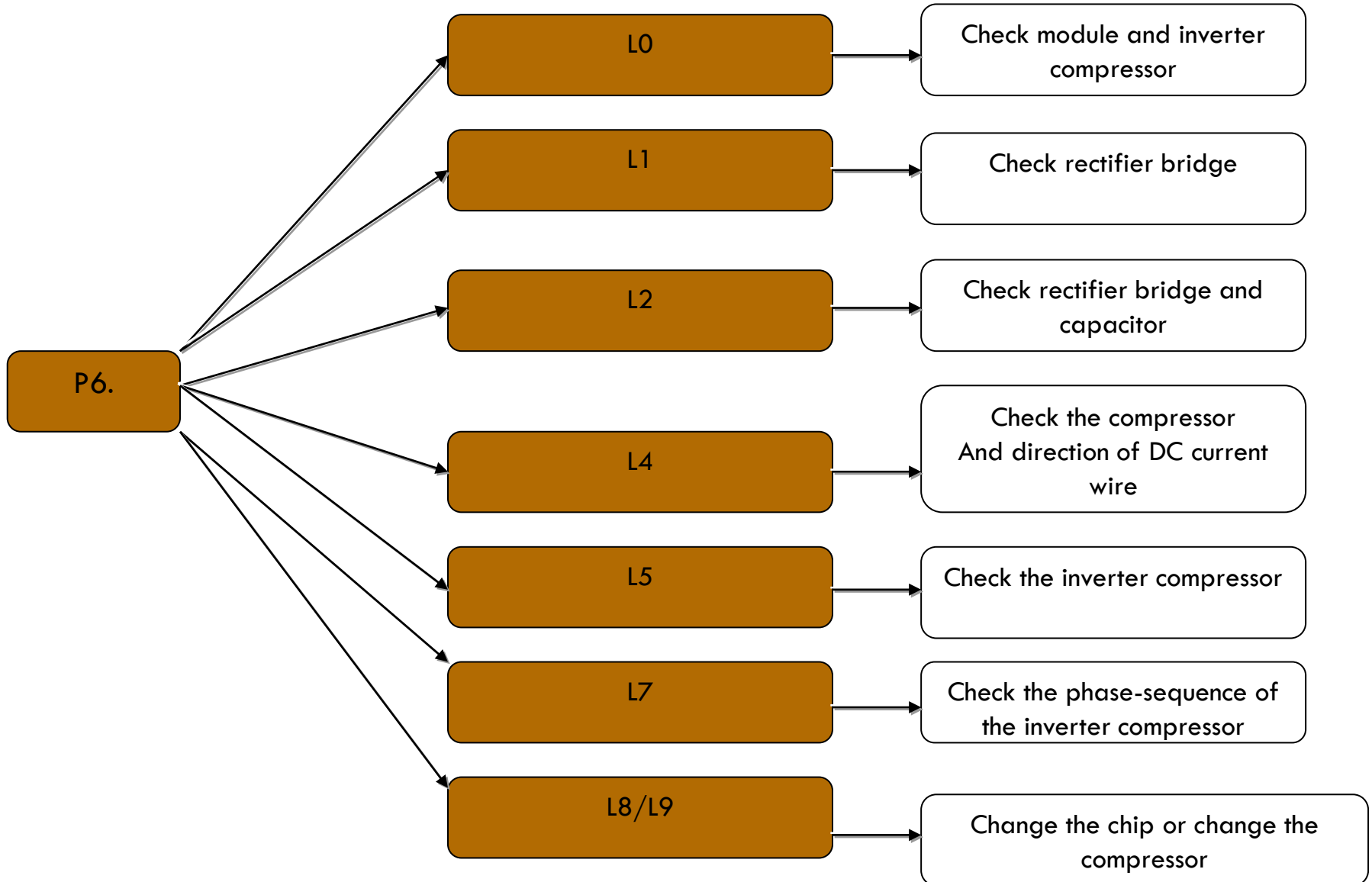

## ***L0: Inverter compressor malfunction***

**1. Over current protection (auto-recover): Lights flash once every 3s.  
Usually cause by bad outdoor unit heat exchanging condition.**

**Solution: improve the heat exchanging condition.**

**2. Over load protection (auto-recover) : Lights flash 4 times every 3s.  
Usually cause by bad outdoor unit heat exchanging condition.**

**Solution: improve the heat exchanging condition.**

## ***L0: Inverter compressor malfunction***

**3、 Over heat protection (auto-recover): Lights flash 5 times every 3s.  
Check if the module heat sink is cooled properly, check if the thermal silicone on module is coated evenly.**

**Solution: thermal silicone on module must be coated evenly after replacing module board.**

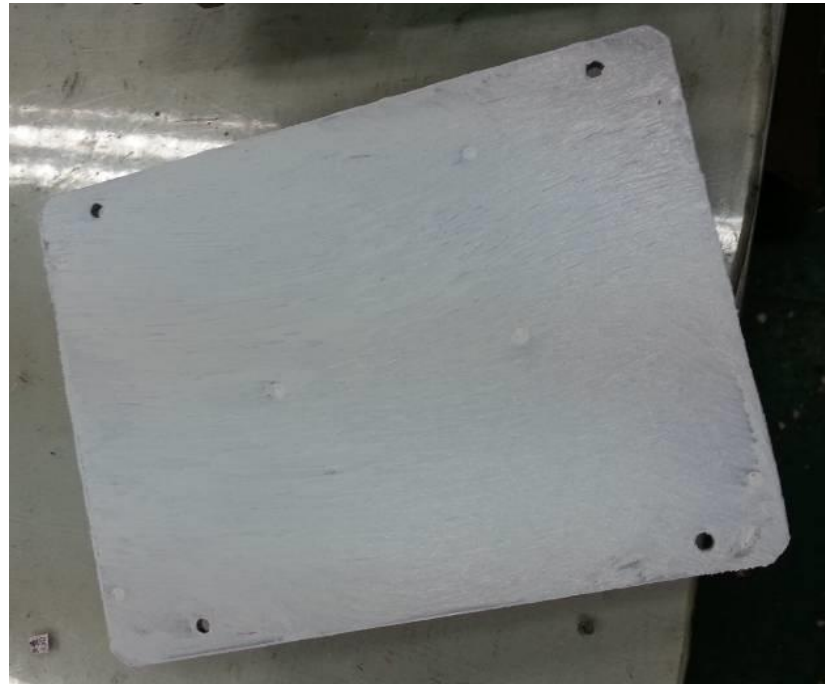

## *L0: Inverter compressor malfunction*

**4、 Measure the voltage of P1&N1 terminal on inverter module board, normal value is 310V .**

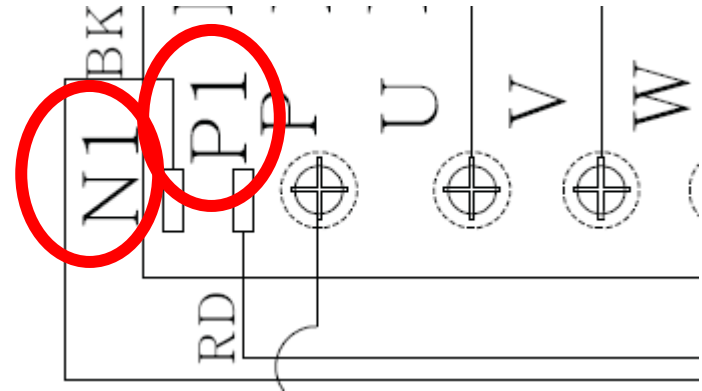
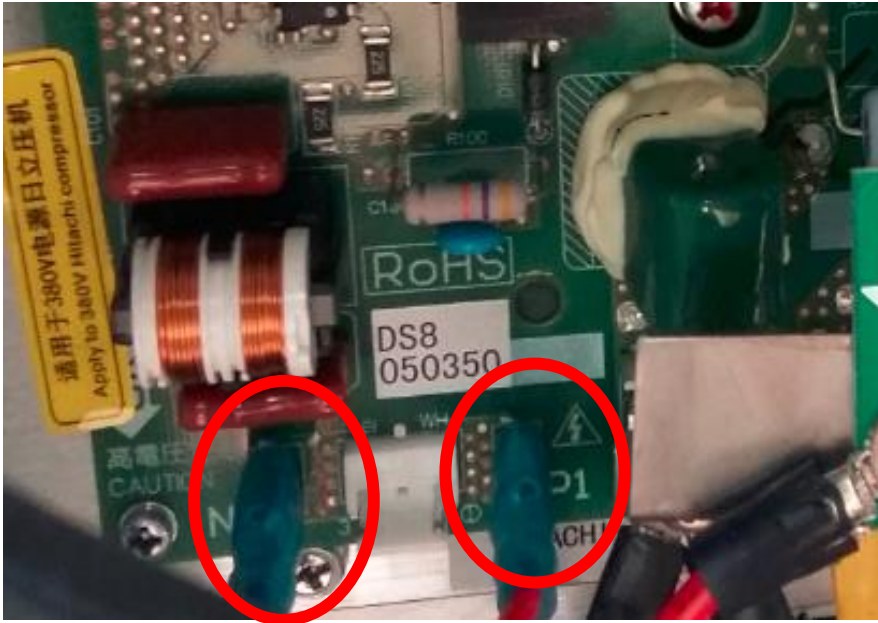

## *L0: Inverter compressor malfunction*

**5、 Measure the voltage of P&N terminal on inverter module board, normal value is 510~580V .**

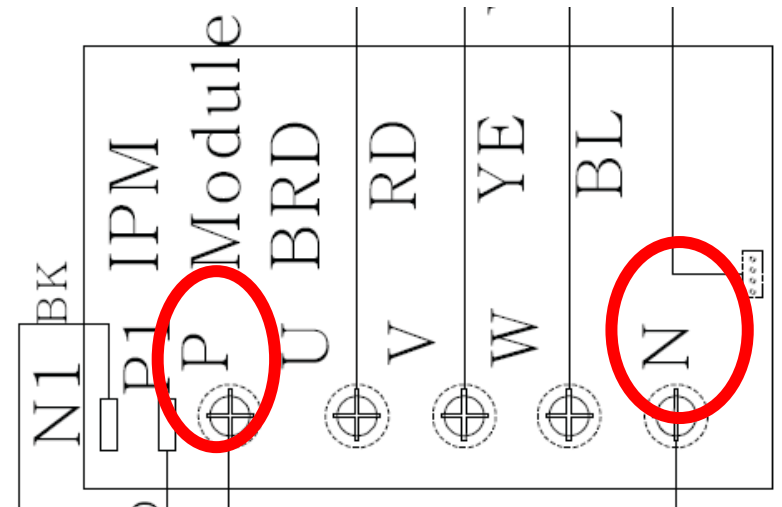
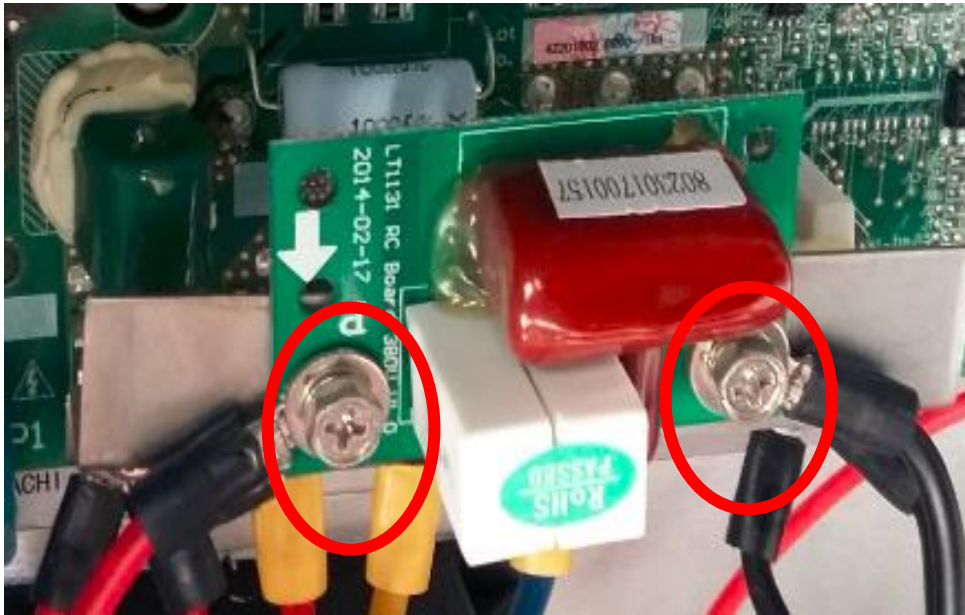

## ***L0: Inverter compressor malfunction***

**6、 Pull out U,V,W from compressor, measure the resistance between any two of P/N/U/V/W. All the values are infinity..**

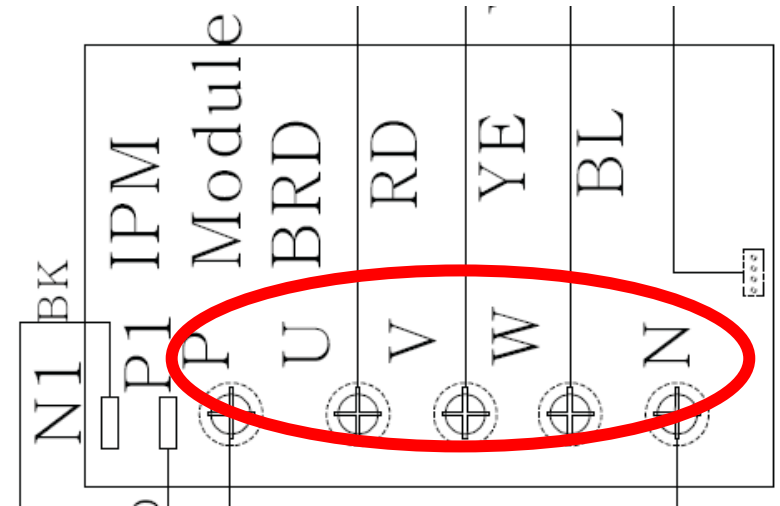
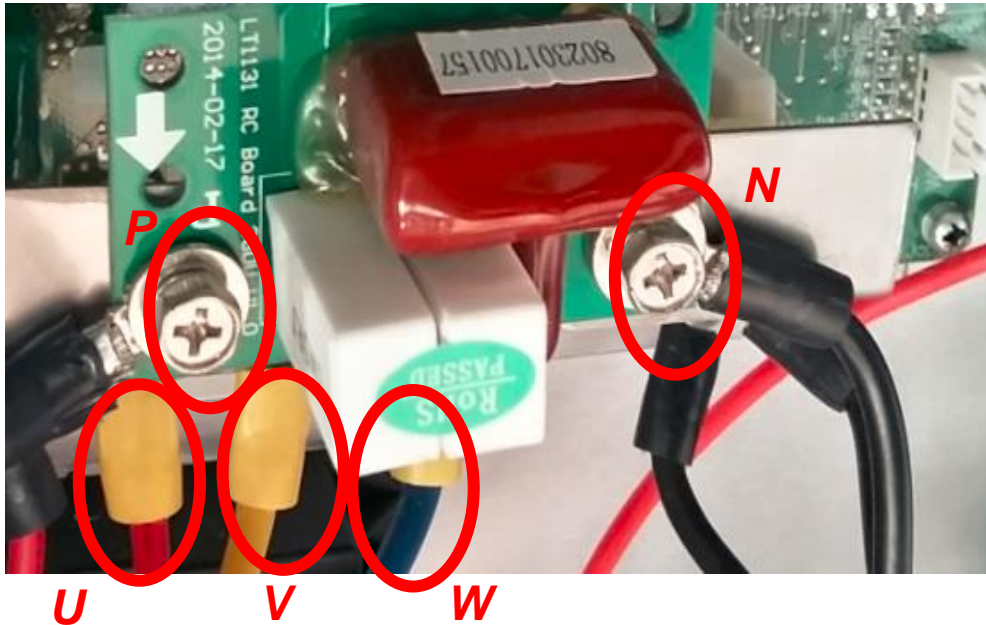

**Solution: If anyone is 0 , replace inverter module board, otherwise go to next step.**

## ***L0: Inverter compressor malfunction***

**7、 Measure each two of compressor U,V,W terminal resistance, U&V,U&W,V&W, the normal value is 0.9~5Ω; Measure U,V,W and ground resistance, the normal value is infinity.**

**Solution: If all the resistances are normal, then go to next step. Otherwise, anyone resistance is abnormal, replace the inverter compressor .**

**L1: DC generatrix low voltage protection**  
**L4: MCE malfunction/simultaneously/cycle loop**

**1. Check DC voltage between P and N terminal, normal value is 510~580V.**

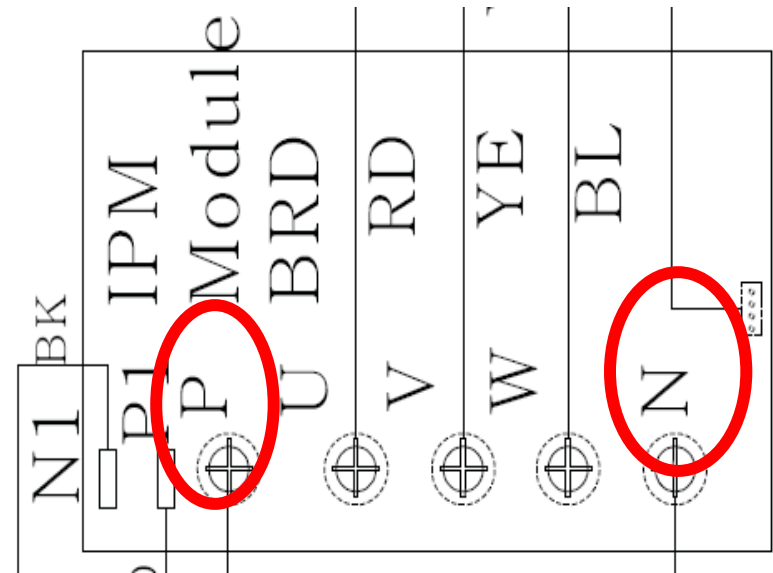
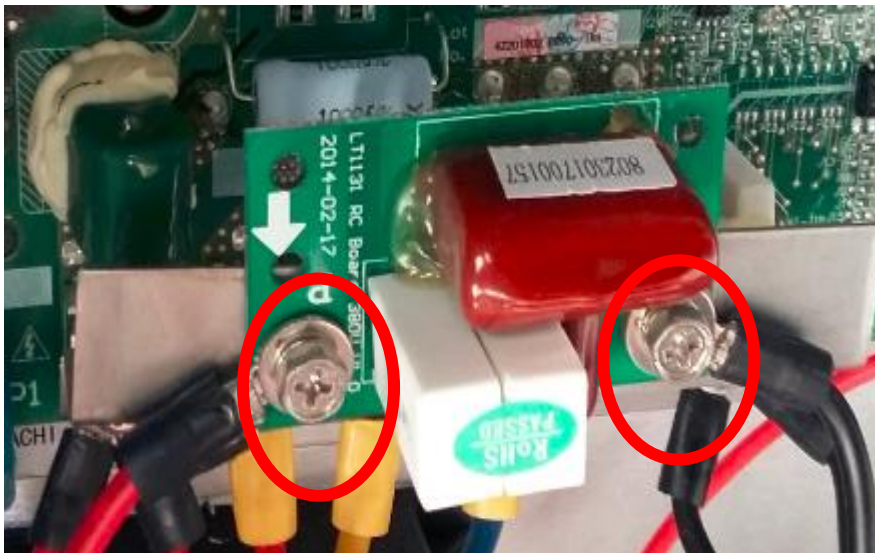

**Solution: If voltage is lower than 510V, go to next step.**

**L1: DC generatrix low voltage protection**  
**L4: MCE malfunction/simultaneously/cycle loop**

**2. Check whether rectifier wire connection is loose .**

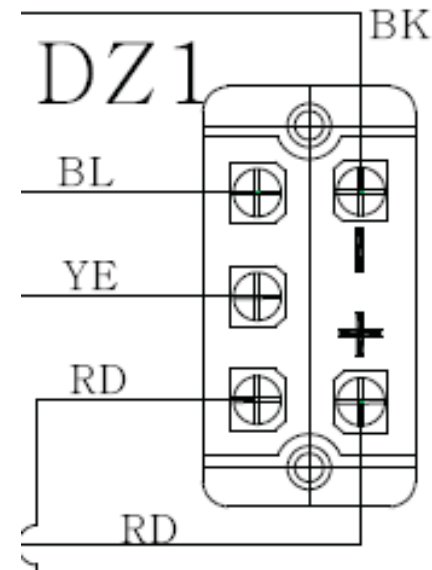
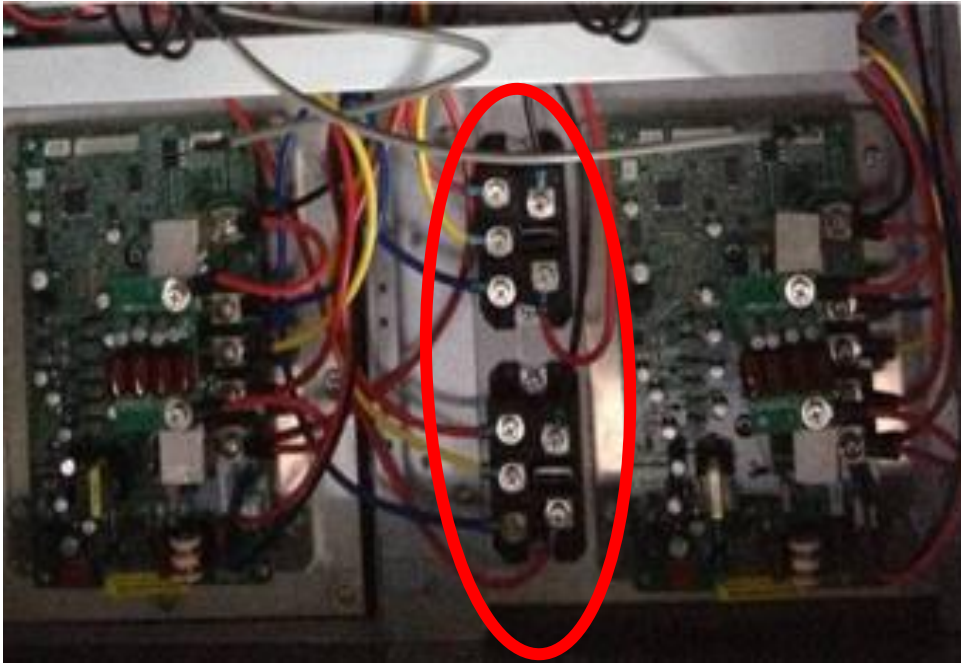

**Solution: If it loose, fasten it, otherwise replace the main PCB**

## L2: DC generatrix high voltage protection

1. Check DC voltage between P and N terminal, normal value is 510~580V.

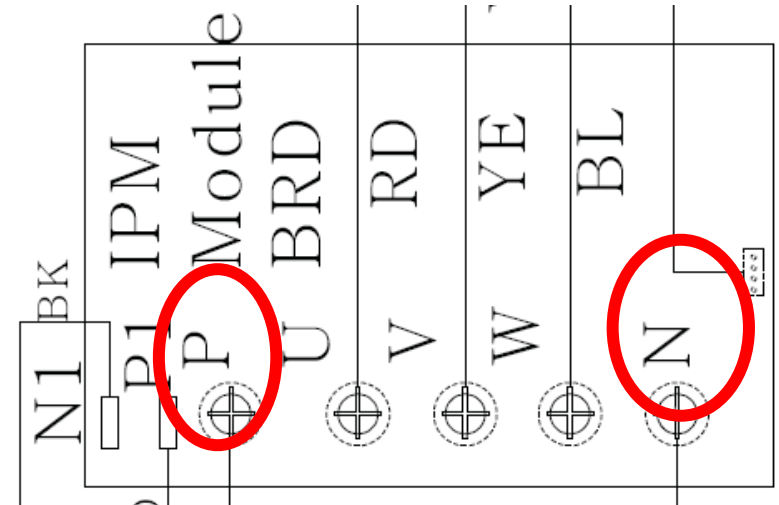

**Solution:** If it is higher than 580V, go to next step.

## ***L2: DC generatrix high voltage protection***

**2. Check the voltage of two electric capacitor, normal value is 510~580V**



**Solution: If the value is not in the operation range, it means power supply for capacitor has problem, please check power supply whether it is too high or stable. If the voltage is normal, go to next step.**

## *L2: DC generatrix high voltage protection*

**3. Measure the voltage between input and output if inverter compressor's contactor when compressor is running (Normal value is 0V)**

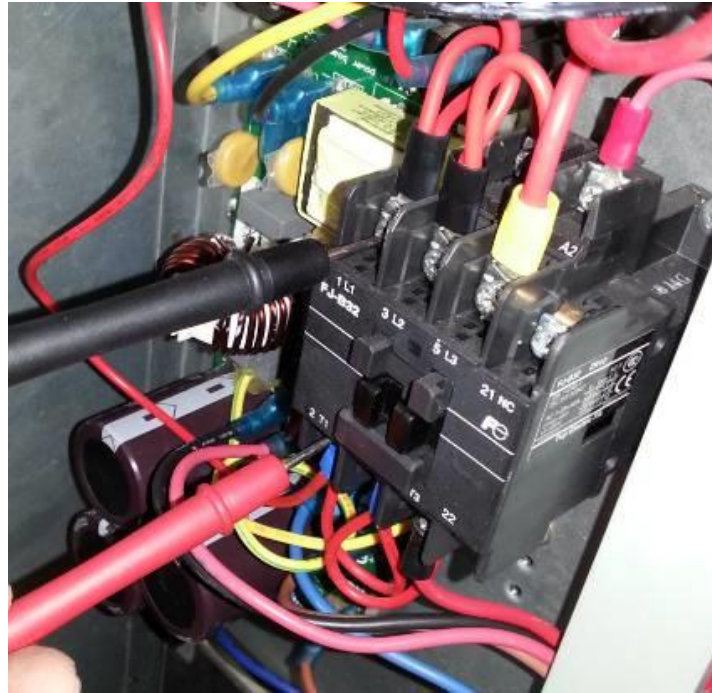

**Solution: If the voltage is not 0, then replace the contactor, otherwise change the main PCB.**

## ***L5: Zero speed protection***

**Check the wiring of inverter compressor.**

**Solution: if wiring is wrong, then correct it. Otherwise replace the inverter module board.**

## ***L7: Wrong phase protection***

**Check the wiring of inverter compressor.**

**Solution: if wiring is wrong, then correct it. Otherwise replace the inverter module board.**

***L8: Speed difference >15Hz protection between the front and the back clock***  
***L9: Speed difference >15Hz protection between the real and the setting speed***

**Solution: Same as L0, replace inverter module board.**

## 03 Indoor error code

## Indoor unit error code

**All lamps off: indoor unit is in standby mode**



DEF lamp is on:  
Anti cold air or in defrosting mode

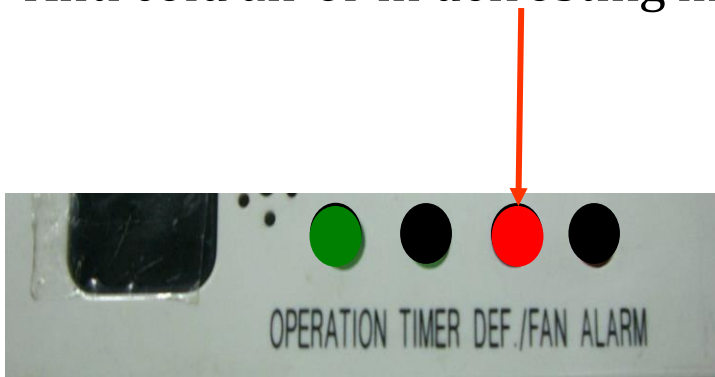

TIMER lamp is on:  
Timer function is on

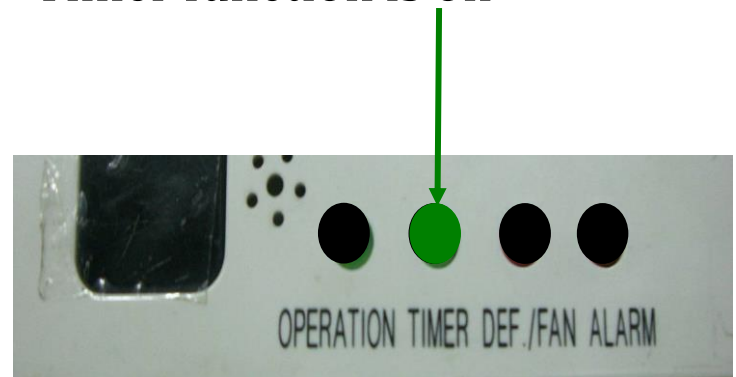

## Indoor unit error code

### Defrost lamp flash



Mode conflict :

cooling or heating can be not realized by the same system at the same time. Heating mode has priority (It can be change on outdoor PCB):

Rules:

- Outdoor unit is running in cooling mode, when received heating requirement, outdoor unit change to heating mode and the indoor units which are in cooling mode will display mode conflict;
- Outdoor unit is running in heating mode, when received cooling or fan only requirement, outdoor unit don't response to the requirement. The indoor unit required cooling mode or fan only will display mode conflict;

	Cooling	Heating	Fan only	OFF
Cooling mode	No	Conflict	No	No
Heating mode	Conflict	No	Conflict	No
Fan only mode	No	Conflict	No	No
OFF	No	No	No	No

## ***Indoor unit error code***

<b>LED display</b>	<b>LED light</b>	<b>Meanings</b>
<b>FE</b>	<b>TIMER and RUN both flash 4Hz,</b>	<b>No address when indoor unit first time power on</b>
<b>E1</b>	<b>TIMER flashes at 4Hz</b>	<b>Communication error between indoor and outdoor units</b>
<b>E2</b>	<b>RUN flashes 4Hz</b>	<b>Temperature sensor T1 error</b>
<b>E3</b>	<b>RUN flashes 4Hz</b>	<b>Temperature sensor T2 error</b>
<b>E4</b>	<b>RUN flashes 4Hz</b>	<b>Temperature sensor T2B error</b>
<b>E5</b>	<b>ALARM flashes 0.5Hz,</b>	<b>Outdoor unit error</b>

## ***Indoor unit error code***

<b>LED display</b>	<b>LED light</b>	<b>Meanings</b>
<b>E6</b>	/	<b>Zero crossing detection error</b>
<b>E7</b>	<b>DEFOST flashes 0.5Hz,</b>	<b>EEPROM error</b>
<b>E8</b>	/	<b>Indoor fan motor error</b>
<b>E9</b>	/	<b>Wired controller communication error</b>
<b>EE</b>	<b>ALARM flashes 4Hz</b>	<b>Water level alarm error</b>
<b>EF</b>	<b>DEFOST flashes 4Hz</b>	<b>Mode conflict</b>

## Indoor unit error code

Lamp		Meaning
<b>OPERATION</b>	ON	Indoor unit is normally operation.
	OFF	Indoor unit is OFF
	Flash	Indoor unit is Standby
	Flash rapidly	Temperature sensor malfunction
<b>TIMER</b>	ON	Timer function is on
	Flash rapidly	Communication malfunction between indoor and outdoor unit
<b>DEF./FAN</b>	ON	Indoor unit is in anti-cold model or system is defrosting
	Flash rapidly	Mode confliction
	Flash	EEPROM malfunction
<b>ALARM</b>	Flash rapidly	Water-level switch abnormal
	Flash	Outdoor unit malfunction
<b>Operation &amp;Timer</b>	Flash simultaneously	There is no address

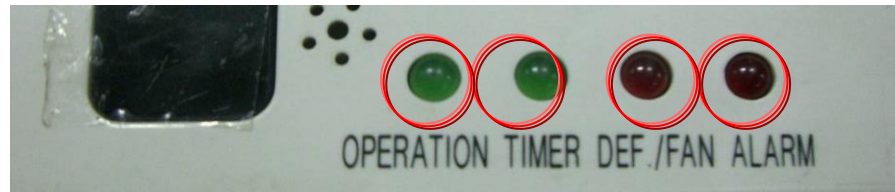

# 04 Indoor Troubleshooting

***FE: No address when indoor unit first time power on***

**When first power on, outdoor unit will distribute address to indoor unit automatically, if it show FE, check SW3 4<sup>th</sup> switch, it is in ON state or OFF state.**

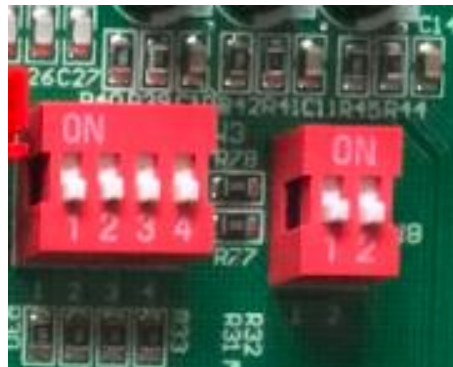

**Solution: If it in ON state, change it in OFF then repower on the system, otherwise replace the PCB**

***E1: Communication error between indoor and outdoor units***

**1. Check indoor and outdoor unit communication terminal connection wire is loose, short circuit or connect wrong.**



**Solution: Reconnect it, otherwise go to next step.**

## ***E1: Communication error between indoor and outdoor units***

### **2. Check PQE connector on PCB is loose or not**



**Solution: If the plug is loose, reconnect it, otherwise go to next step.**

***E1: Communication error between indoor and outdoor units***

**3. Check indoor unit communication wire, there is short circuit, if there is short circuit, all indoor units will show E1.**

**Solution: If change the communication wire, otherwise change this indoor unit PCB.**

## E2,E3,E4 Sensor error

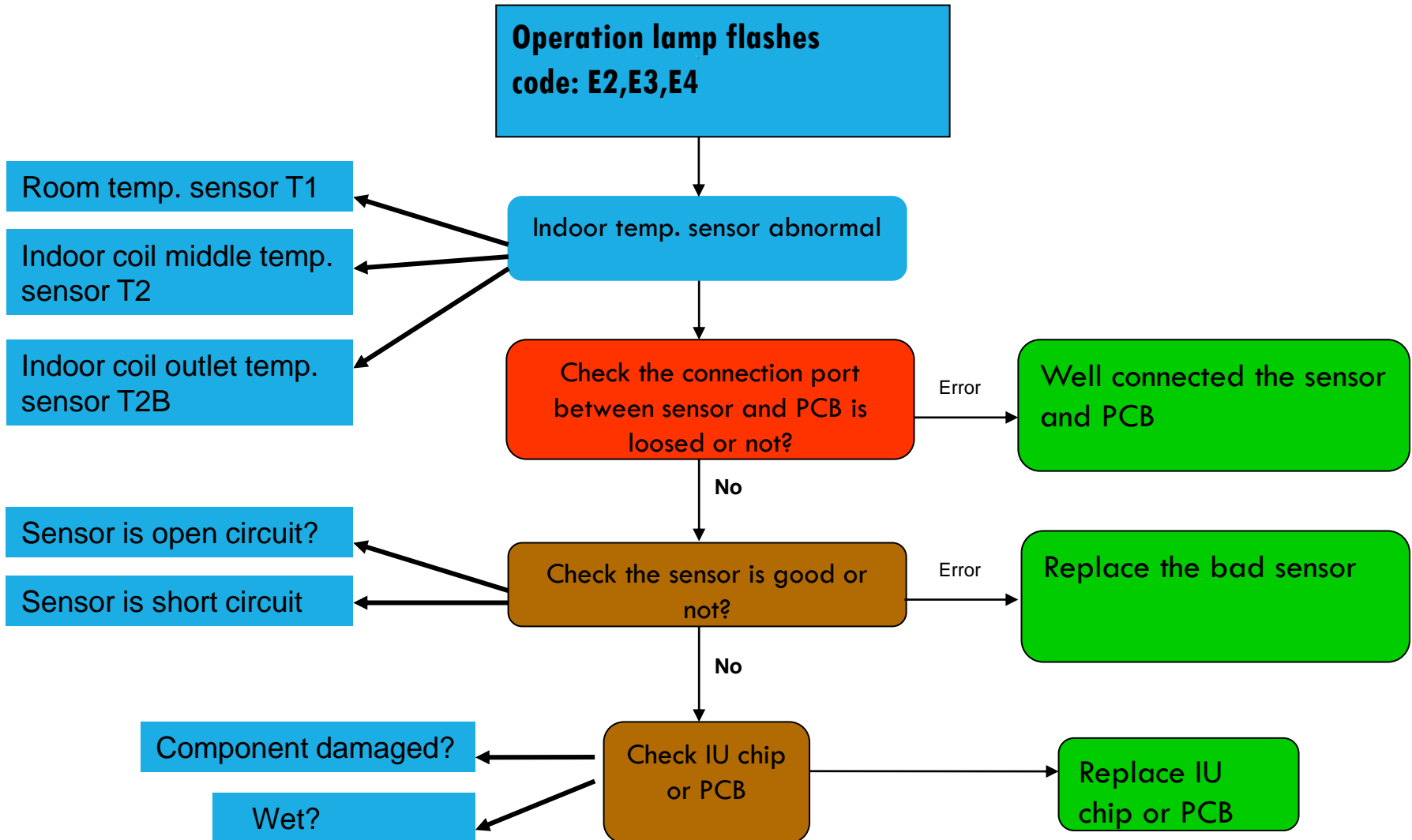

## ***E2,E3,E4 Sensor error***

**1. Check the sensor connector on PCB is loose,**

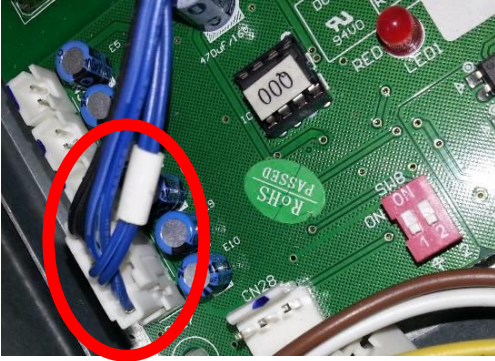

**Solution: If the plug is loose, reconnect it, otherwise go to next step.**

**2. Pull off the connector, use one multimeter to measure the resistance**

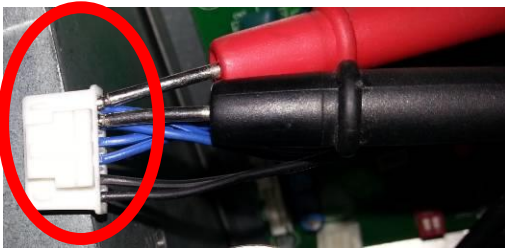

**Solution: If the resistance is abnormal, change the sensor, otherwise replace main PCB**

***E5: Outdoor unit error***

**Please refer to outdoor unit error and troubleshooting**

## EE: Water level alarm error

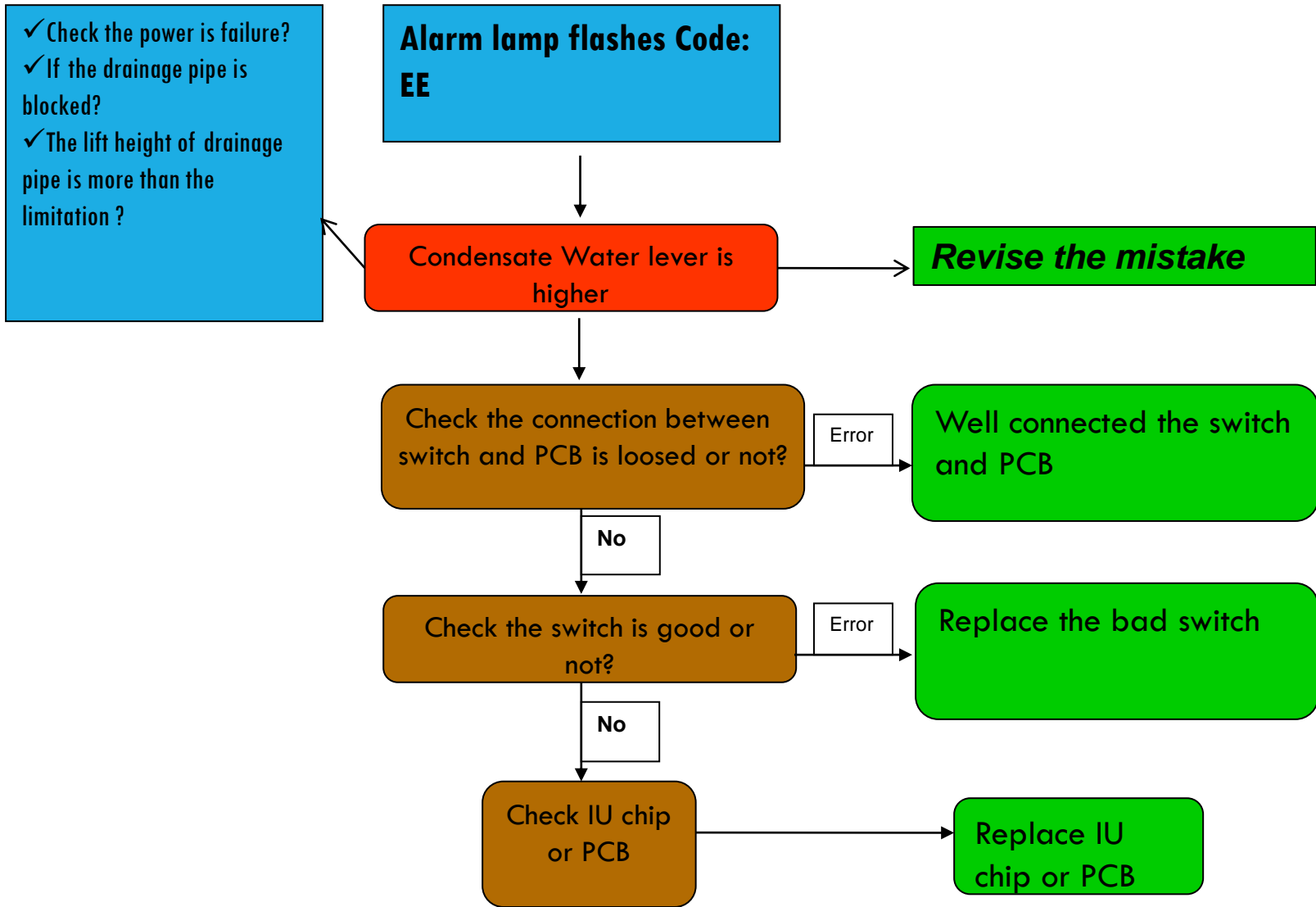

## ***EE: Water level alarm error***

**1. Check the water switch connector is loose, if loose, reconnect it, otherwise go to next step;**



**2. Pull of the connector, and use one short circuit wire instead, if the error disappear, replace the water level switch, otherwise replace the PCB**



## E7: EEPROM error

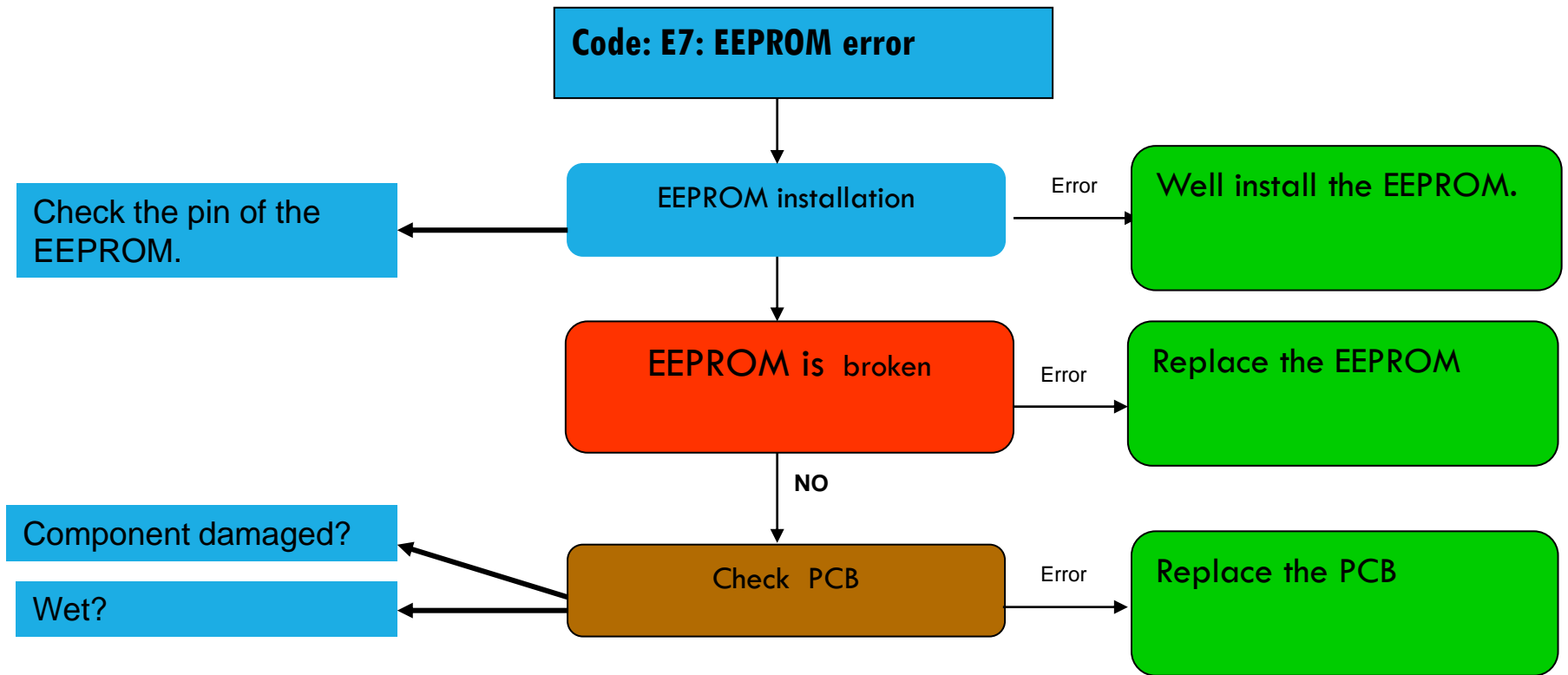

Poor performance in cooling or heating

wrong selection of refrigerant pipe, indoor EXV or branch joint, the refrigerant distribution among the indoor units is quite imbalance;

- 1.Low designed load
- 2.Long refrigerant pipe and big height difference
- 3.The match ratio is more than 130%

- 1.Leakage in the system;
- 2.Additional refrigerant is not charged enough

- 1.The power of some indoor units is failure
- 2.Address code of indoor units is repeated or incorrect, check the quantity of indoor units with centralized controller or check button on outdoor PCB

Heat exchange of indoor or outdoor unit is not good. E.g.: dirty, bad ventilation.....

- 1.Indoor (EXV) doesn't work, are there noise and temp. difference?
- 2.Some indoor units have no power

## The suction pipe Frost

### The suction pipe Frost

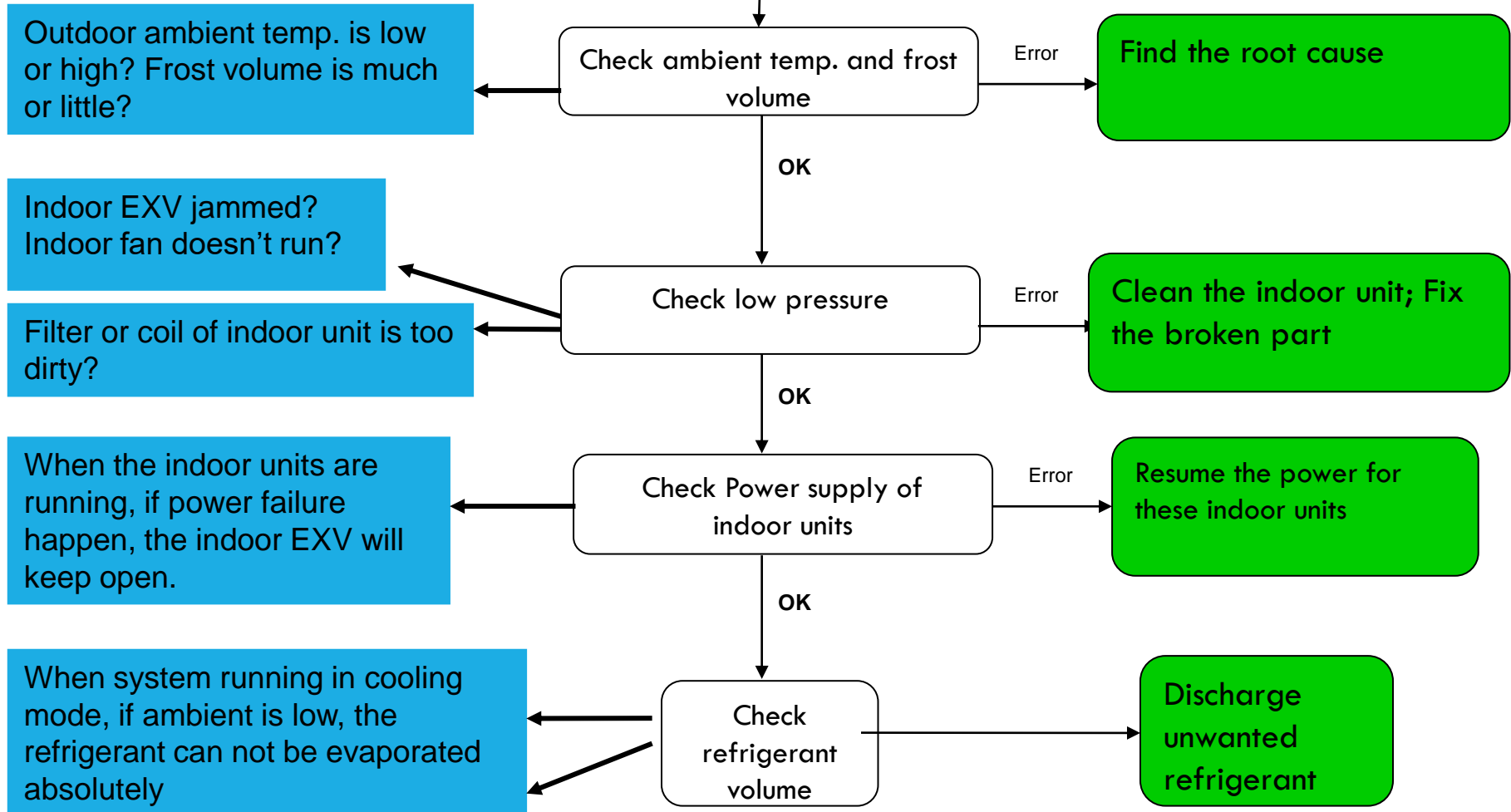

**Thank you**

